



OUR GLOBAL
COMPETENCE
CENTRES

 APOLLO DISPLAY
TECHNOLOGIES



 DISTEC



 DISPLAY
TECHNOLOGY



Datasheet

Ortustech

COM35H3P58ULC

OR-20-044

Specifications for
Blanview TFT-LCD Monitor
(3.5" QVGA 240 x RGB x 320 Landscape)

Version 1.0

MODEL COM35H3P58ULC

(Please be sure to check the specifications latest version.)

Customer's Approval

Signature:

Name:

Section:

Title:

Date:

ORTUSTECH

TOPPAN PRINTING CO.,LTD.

Electronics Division

Ortus Subdivision

Approved by

_____ *S. Euchi*

Checked by

_____ *T. Matsuzaki*

Prepared by

_____ *M. Tojo*

Version History

Ver.	Date	Page	Description
0.0	Jul.10,2020	-	- Tentative issue
1.0	Apr.9.2021	-	- First issue
△ ×12		P.7	3.1 Dimensions
		Add	Weight
		P.11	5. Absolute Maximum Rating
		Add	Rating
		P.12	7.1.1 Display Module
		Add	Rating
		Add	7.1.2 Backlight
		Add	Rating
		Add	7.2 AC Characteristics
		Add	Rating
		P.14	7.3 Input Timing Characteristics
		Add	Rating
		P.19	10.1 Optical Characteristics
		Add	Rating
		P.20	White Chromaticity Range
P.20	10.2 Temperature Characteristics		
Add	Rating		
P.23	12. Reliability Test		
Add	number of failures / number of examinations		
Correct	Temperature / humidity profile diagram		
P.25	13. Packing Specifications		
Add	Packing Specifications		
P.29	14.5 Precautions for Peeling off the Protective film		
Add	Work Method		

Contents

1. Application	4
2. Outline Specifications		
2.1 Features of the Product	5
2.2 Display Method	5
3. Dimensions and Shape		
3.1 Dimensions	7
3.2 Outward Form	8
3.3 Serial No. print (S-print)	9
4. Pin Assignment	10
5. Absolute Maximum Rating	11
6. Recommended Operating Conditions	11
7. Characteristics		
7.1 DC Characteristics		
7.1.1 Display Module	12
7.1.2 Backlight	12
7.2 AC Characteristics	12
7.3 Input Timing Characteristics	14
7.4 Driving Timing Chart	15
7.5 Example of Driving Timing Chart (fCLK=5.6MHz)	16
8. Power ON/OFF Sequence		
8.1 Power ON Sequence	17
8.2 Standby / Power OFF Sequence	17
9. LED Circuit	18
10. Characteristics		
10.1 Optical Characteristics	19
10.2 Temperature Characteristics	20
11. Criteria of Judgment		
11.1 Defective Display and Screen Quality	21
11.2 Screen and Other Appearance	22
12. Reliability Test	23
13. Packing Specifications	25
14. Handling Instruction		
14.1 Cautions for Handling LCD panels	26
14.2 Precautions for Handling	27
14.3 Precautions for Operation	27
14.4 Storage Condition for Shipping Cartons	28
14.5 Precautions for Peeling off the Protective film	29
14.6 Warranty	29
APPENDIX	30

1. Application

This Specification is applicable to 87.9mm (3.5 inch) Blanview TFT-LCD monitor for non-military use.

- ◎ TOPPAN PRINTING makes no warranty or assume no liability that use of this Product and/or any information including drawings in this Specification by Purchaser is not infringing any patent or other intellectual property rights owned by third parties, and TOPPAN PRINTING shall not grant to Purchaser any right to use any patent or other intellectual property rights owned by third parties. Since this Specification contains TOPPAN PRINTING's confidential information and copy right, Purchaser shall use them with high degree of care to prevent any unauthorized use, disclosure, duplication, publication or dissemination of TOPPAN PRINTING's confidential information and copy right.
- ◎ If Purchaser intends to use this Products for an application which requires higher level of reliability and/or safety in functionality and/or accuracy such as transport equipment (aircraft, train, automobile, etc.), disaster-prevention/security equipment or various safety equipment, Purchaser shall consult TOPPAN PRINTING on such use in advance.
- ◎ This Product shall not be used for application which requires extremely higher level of reliability and/or safety such as aerospace equipment, telecommunication equipment for trunk lines, control equipment for nuclear facilities or life-support medical equipment.
- ◎ It must be noted as an mechanical design manner, especial attention in housing design to prevent arcuation/flexureor caused by stress to the LCD module shall be considered.
- ◎ TOPPAN PRINTING assumes no liability for any damage resulting from misuse, abuse, and/or miss-operation of the Product deviating from the operating conditions and precautions described in the Specification.
- ◎ TOPPAN PRINTING is not responsible for any nonconformities and defects that are not specified in this specifications.
- ◎ If any issue arises as to information provided in this Specification or any other information, TOPPAN PRINTING and Purchaser shall discuss them in good faith and seek solution.
- ◎ TOPPAN PRINTING assumes no liability for defects such as electrostatic discharge failure occurred during peeling off the protective film or Purchaser's assembly process.
- ◎ This Product is compatible for RoHS(2.0) directive.

Object substance	Maximum content [ppm]
Cadmium and its compound	100
Hexavalent Chromium Compound	1000
Lead & Lead compound	1000
Mercury & Mercury compound	1000
Polybrominated biphenyl series (PBB series)	1000
Polybrominated biphenyl ether series (PBDE series)	1000
Bis(2-ethylhexyl)phthalate series(DEHP series)	1000
Butyl benzyl phthalate series(BBP series)	1000
Dibutyl phthalate series(DBP series)	1000
Diisobutyl phthalate series(DIBP series)	1000

2. Outline Specifications

2.1 Features of the Product

- 3.5 inch diagonal display, 320 [H] x 240RGB [V] dots.
- 8-bit 16,777,216 color display capability.
- Single power supply operation of 3.3V.
- Built in Timing generator (TG), Counter-electrode driving circuitry and power supply circuit.
- Long life & high bright white LED back-light.
- Blanview TFT-LCD, improved outdoor readability.

	Indoor		Outdoor	
	Readability	Power Efficiency (Battery Life)	Readability	Power Efficiency (Battery Life)
Transmissive	Good	Good	Fair	Poor
Transflective	Fair	Poor	Good	Good
Blanview	Good	Good	Good	Good

2.2 Display Method

Items	Specifications	Remarks
Display type	VA type 16,777,216 colors. Blanview, Normally black.	
Driving method	a-Si TFT Active matrix. Line-scanning, Non-interlace.	
Dot arrangement	RGB horizontal stripe arrangement.	Refer to "Dot arrangement".
Signal input method	8-bit RGB, parallel input.	
Backlight type	Long life & high bright white LED.	
NTSC ratio	50%	

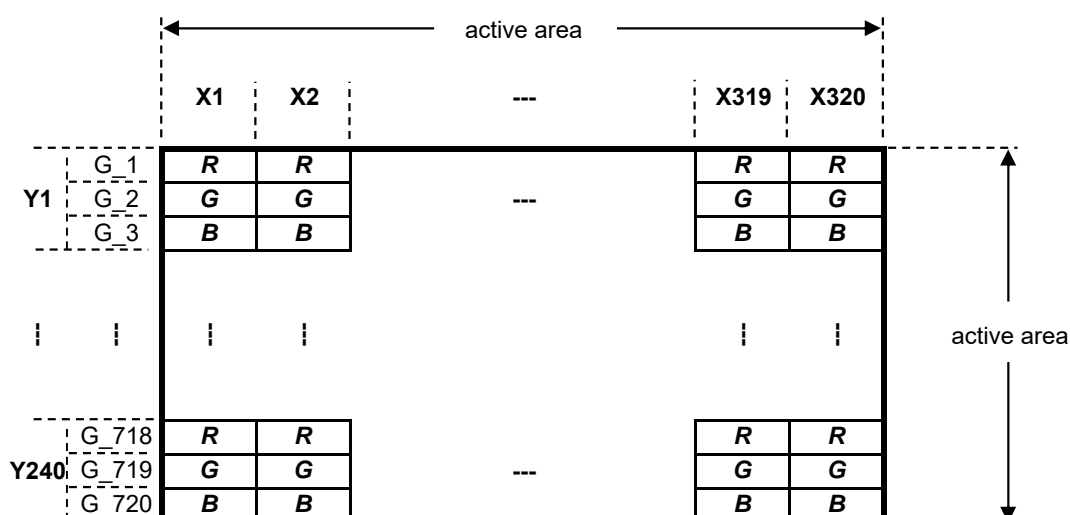

Dot arrangement (FPC cable placed downside)

<Features of Blanview>

- Backlight power consumption required to assure visibility.

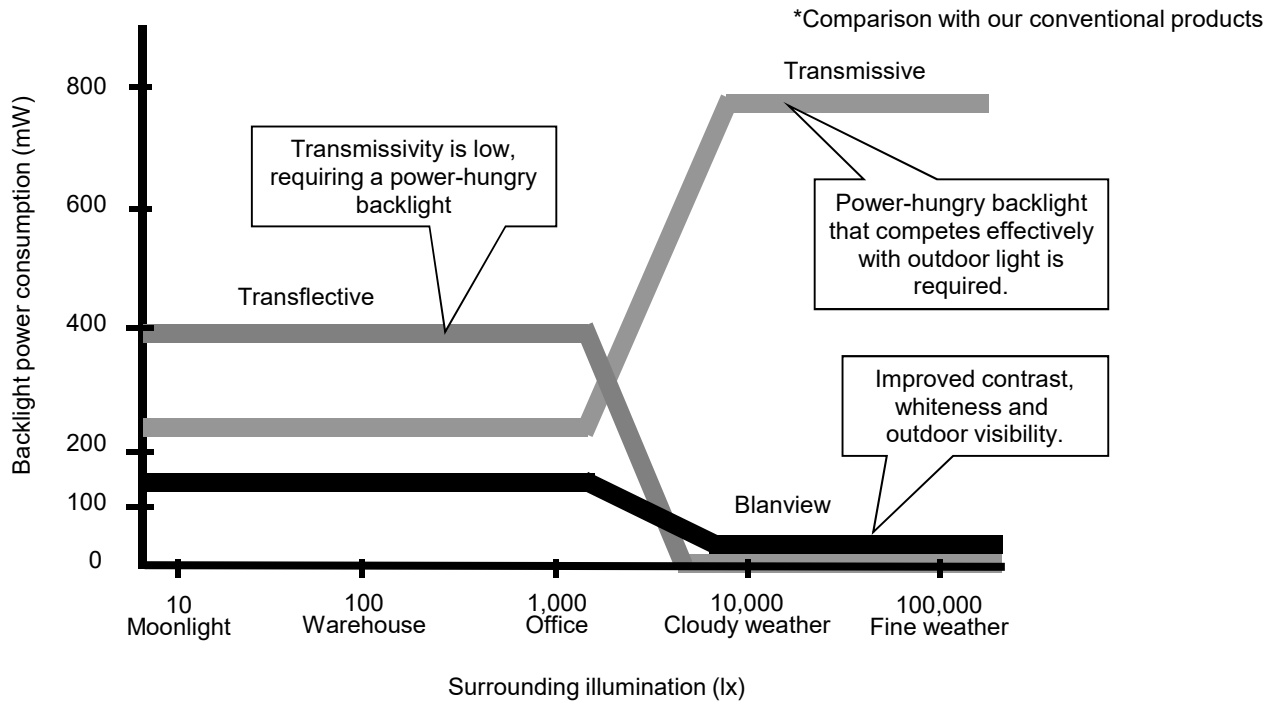

- Contrast characteristics under 100,000lx. (same condition as direct sunlight.)

With better contrast (higher contrast ratio), Blanview TFT-LCD has the best outdoor readability in three different types of TFT-LCD.

Below chart shows contrast value against panel surface brightness. (Horizontal: Panel surface brightness/ Vertical: Contrast value) LCD panel has enough outdoor readability above our Standard line. (TOPPAN PRINTING criteria)

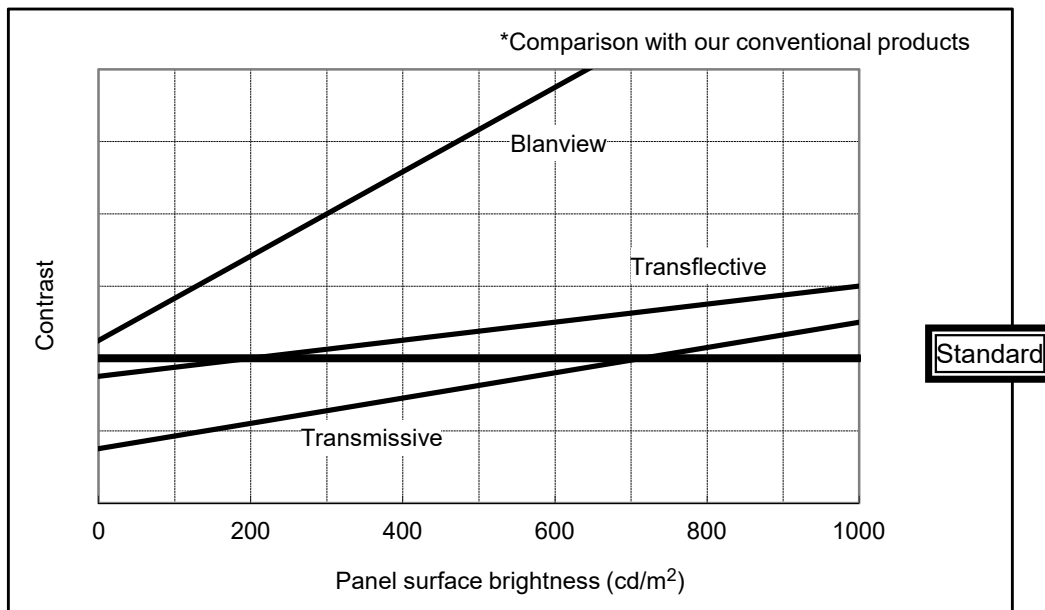

3. Dimensions and Shape

△ 3.1 Dimensions

Items	Specifications	Unit	Remarks
Outline dimensions	79.80[H] × 66.50[V] × 4.90[D]	mm	Exclude FPC cable.
Active area	70.32[H] × 52.74[V]	mm	87.9 mm diagonal.
Number of dots	320[H] × 720[V]	dot	
Dot pitch	219.75[H] × 73.25[V]	μm	
Surface hardness of the polarizer	2	H	Load:2.94N
Weight	40	g	Include FPC cable.

3.2 Outward Form

EC No.	REV. No.	REVISE	DATE (Y:M:D)	APPROVED	CHECKED	PREPARED

(8/32)
20TLM014
Issue: Apr.9,2021

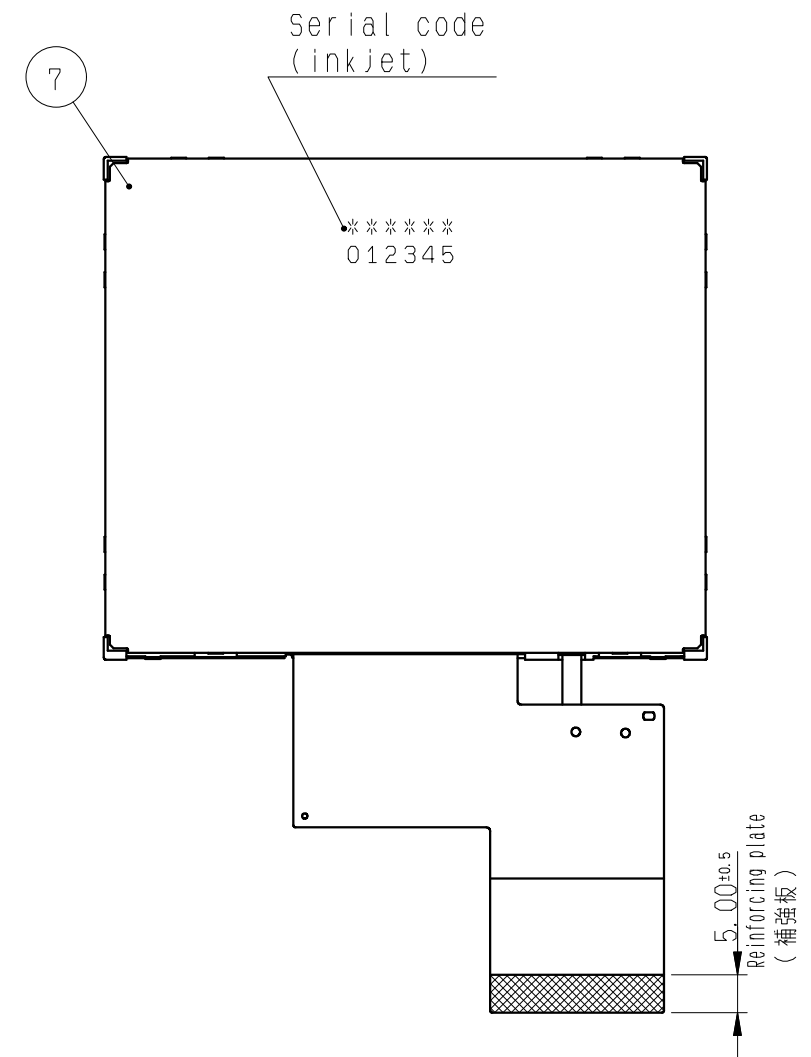
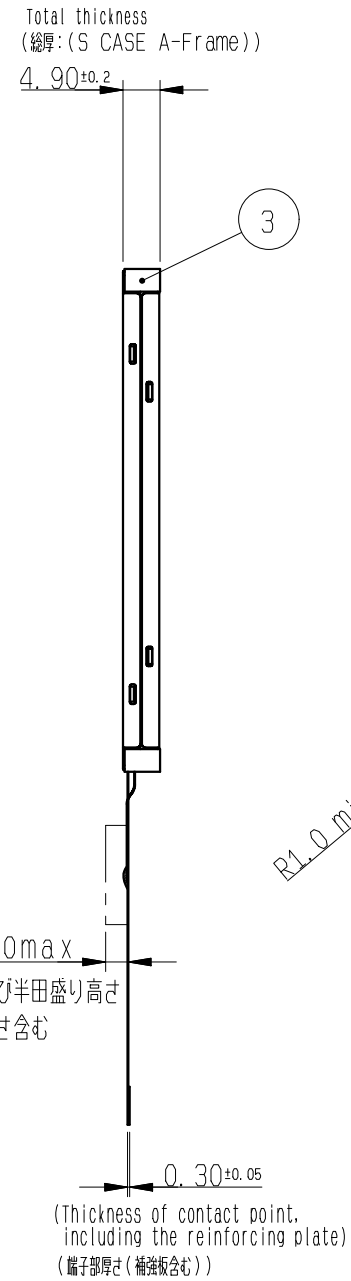
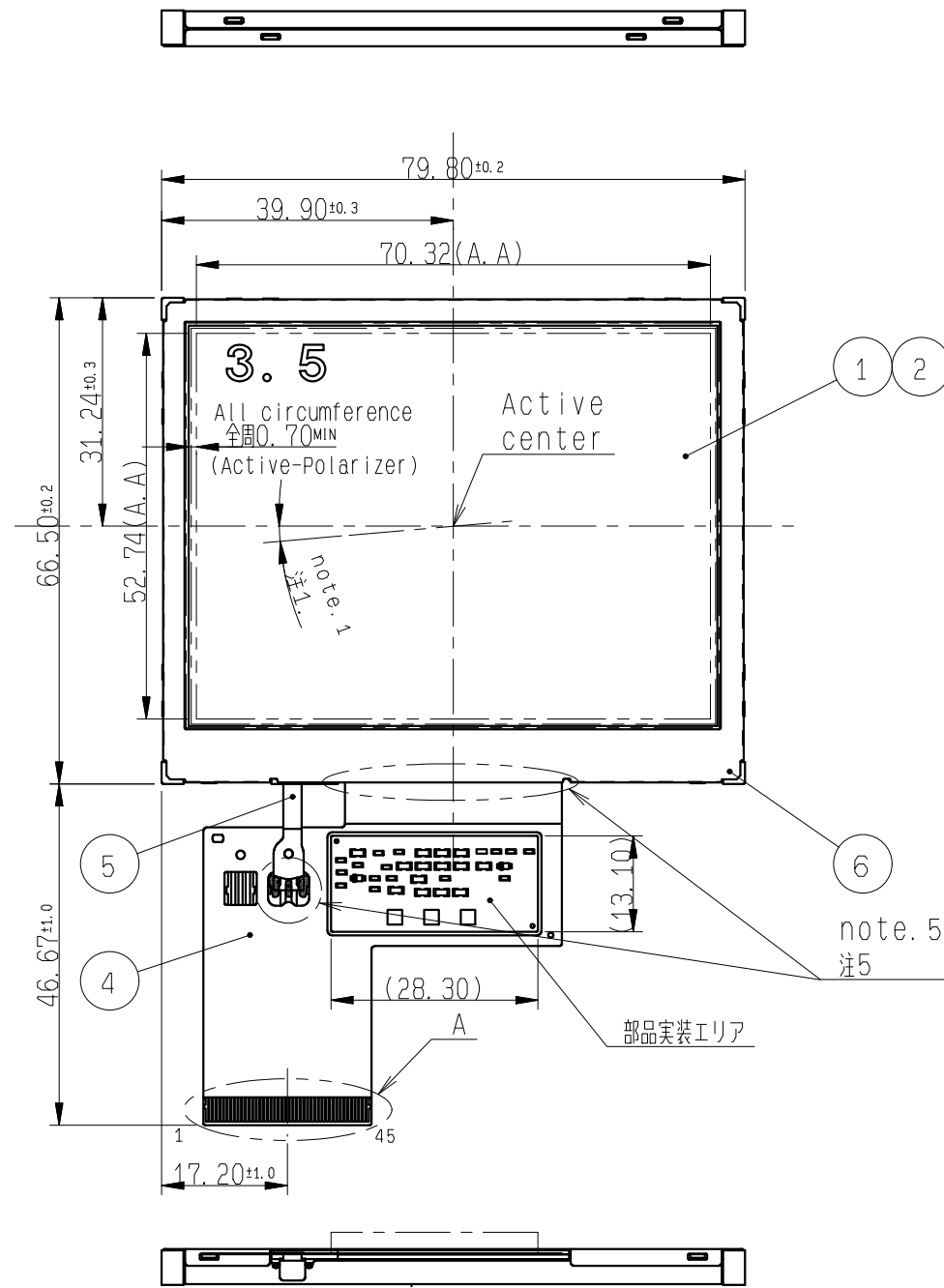

note Angular deviation of LCD cell from the TFT-LCD monitor's reference axis shall be less than $[\pm 50']$.
注1. TFT-LCD PANELの角度スレは、モニター基準軸に対し $[\pm 50']$ 以下とする。

Protective film is affixed on front surface of the screen. Protective film is not protrude from the outline of the monitor.
2. 保護膜が表面側に貼られます。保護膜はモニター外形からはみ出さないものとする。

Recommended FPC connectors
HIROSE : FH12A-45S-0.5SH(55)(Top Contact)
FPC pin assignment differs from a position of Datum Pin of recommended FPC connector. Please notice the difference when designing your circuit with much care.
3. FPCの推奨コネクタの規格を下記に示す。
HIROSE : FH12A-45S-0.5SH(55) (上接点タイプ)
FPCの端子配列が、推奨コネクタ基準ピンと異なっています。回路設計におかれましては、充分ご注意ください。

Burrs direction of S CASE is outward. (Burrs size is less than 0.03mm.)
4. S CASEのバリ方向は外側になります。(MAX0.03mm)
Don't stress to FPC bonding area & the solder area.
5. FPCの圧着部及び半田接続部には負荷が掛からないようご注意ください。

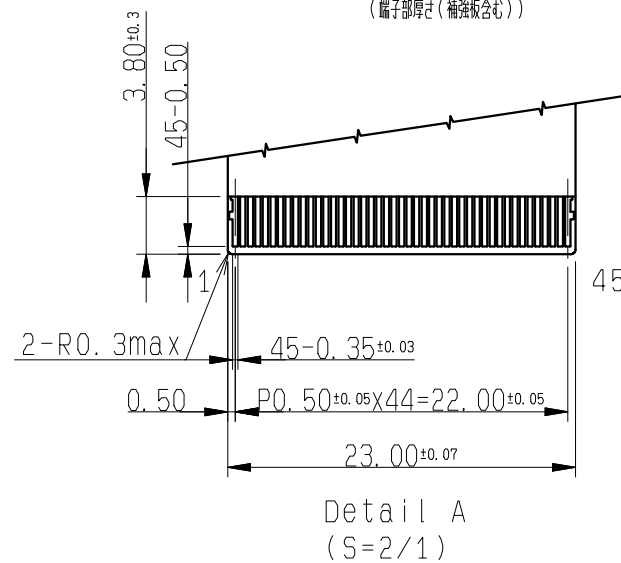

S CASE C	7		SUS (t=0.20)	
S CASE A	6		SUS (t=0.15)	
FPC B	5			Use of LED
FPC A	4		Au/Ni plating AU/Niメッキ	Use of LCD
Frame	3		PC	
Polarizer	2			
TFT-LCD PANEL	1		Glass thickness=0.50+0.50t	
PART NAME	ITEM	PART CODE	MODEL NUMBER	REMARK

APPROVED 尾木	GENERAL TOLERANCE ± 0.5	SCALE 1/1	UNIT mm	TOPPAN TOPPAN PRINTING CO., LTD. DO NOT DUPLICATE, CONFIDENTIAL AND PROPRIETARY
CHECKED 加藤	ISSUE (Y:M:D) 20:06:24	MODEL COM35H3P58U**		
CHECKED	NAME			DRAWING No. RJD600507D301
DESIGN 前田創	OUTLINE-D3P58			REV. /
DRAW 前田創				SHEET /

3.3 Serial № print (S-print)

1) Display Items

S-print indicates the least significant digit of manufacture year (1digit), manufacture month with below alphabet (1letter), model code (5characters), serial number (6digits).

* Contents of Display

*	*	*****	*****
-	-	-	-
a	b	c	d

Contents of display				
a	The least significant digit of manufacture year			
b	Manufacture month	Jan-A Feb-B Mar-C Apr-D	May-E Jun-F Jul-G Aug-H	Sep-I Oct-J Nov-K Dec-L
c	Model code	35QFC (Made in Japan) 35QGC (Made in Malaysia)		
d	Serial number			

* Example of indication of Serial № print (S-print)

•Made in Japan

1H35QFC000125

means "manufactured in August 2021, 3.5" QF type, C specifications, serial number 000125"

•Made in Malaysia

1H35QGC000125

means "manufactured in August 2021, 3.5" QG type, C specifications, serial number 000125"

2) Location of Serial № print (S-print)

Refer to 3.2 "Outward Form".

3)Others

Please note that it is likely to disappear with an organic solvent about the Serial print.

4. Pin Assignment

No.	Symbol	Function
1	VSS	GND.
2	VSS	GND.
3	VDD	Power supply.
4	VDD	Power supply.
5	D00	Display data(R). 00h: Black D00:LSB D07:MSB Driver has internal gamma conversion. Connect unused pins to GND.
6	D01	
7	D02	
8	D03	
9	D04	
10	D05	
11	D06	
12	D07	
13	D10	Display data(G). 00h: Black D10:LSB D17:MSB Driver has internal gamma conversion. Connect unused pins to GND.
14	D11	
15	D12	
16	D13	
17	D14	
18	D15	
19	D16	
20	D17	
21	D20	Display data(B). 00h: Black D20:LSB D27:MSB Driver has internal gamma conversion. Connect unused pins to GND.
22	D21	
23	D22	
24	D23	
25	D24	
26	D25	
27	D26	
28	D27	
29	VSS	GND.
30	CLK	Clock signal.Latching data at the falling edge.
31	STBYB	Standby signal input. (Hi:Normal operation, Lo:Standby operation)
32	HSYNC	Horizontal sync signal input. (Low active)
33	VSYNC	Vertical sync signal input. (Low active)
34	DE	Input data effective signal. (It is effective for the period of "Hi")
35	NC	OPEN.
36	VSS	GND.
37	NC	OPEN.
38	NC	OPEN.
39	NC	OPEN.
40	NC	OPEN.
41	BLL2	Backlight drive (cathode side)
42	BLL1	Backlight drive (cathode side)
43	BLH	Backlight drive (anode side)
44	LR	Left/Right Display reverse(Hi or OPEN:normal display, Low:inversion display)
45	UD	Up/Down Display reverse(Hi or OPEN:normal display, Low:inversion display)

- Recommended connector: HIROSE ELECTRIC FH12 series [FH12A-45S-0.5SH(55)]
- Please make sure to check a consistency between pin assignment in "3.2 Outward Form" and your connector pin assignment when designing your circuit. Inconsistency in input signal assignment may cause a malfunction.
- Since FPC cable has gold plated terminals, gilt finish contact shoe connector is recommended.



5. Absolute Maximum Rating

VSS=0V

Item	Symbol	Condition	Rating		Unit	Applicable terminal
			MIN	MAX		
Supply voltage	VDD	Ta=25° C	-0.3	5.0	V	VDD
Input voltage for logic	VI		-0.3	VDD+0.3	V	CLK, VSYNC, HSYNC, DE, D[27:20], D[17:10], D[07:00], STBYB, LR, UD
LED direction current of order	IL		--	200	mA	BLH - BLL1/BLL2
Storage temperature range	Tstg		-40	95	°C	
Storage humidity range	Hstg	Non condensing in an environmental moisture at or less than 40° C90%RH.				

6. Recommended Operating Conditions

VSS=0V

Item	Symbol	Condition	Rating			Unit	Applicable terminal
			MIN	TYP	MAX		
Supply voltage	VDD		3.0	3.3	3.6	V	VDD
Input voltage for logic	VI	VDD=3.0 to 3.6V	0	--	VDD	V	CLK, VSYNC, HSYNC, DE, D[27:20], D[17:10], D[07:00], STBYB, LR, UD
Operating temperature range	Top	Note	-30	25	85	°C	Panel surface temperature
Operating humidity range	Hop	Ta ≤ 40° C	20	--	85	%	
		Ta > 40° C	Non condensing in an environmental moisture at or less than 40° C85%RH.				

Note : This monitor is operatable in this temperature range. With regard to optical characteristics, refer to Item "10. CHARACTERISTICS".

7. Characteristics

7.1 DC Characteristics

△ 7.1.1 Display Module

(Unless otherwise noted, Ta=25°C, VDD=3.3V, VSS=0V)

Item	Symbol	Condition	Rating			Unit	Applicable terminal
			MIN	TYP	MAX		
Input voltage for logic	VIH	VDD=3.0 to 3.6V	0.7×VDD	--	VDD	V	CLK,VSYNC,HSYNC, DE,D[27:20],D[17:10], D[07:00],STBYB, LR,UD
	VIL		0	--	0.3×VDD	V	
Pull up resistor value	Rpu		--	100	--	kΩ	LR,UD
Current consumption	IDD	Input Timing = TYP Color bar display	--	22	44	mA	VDD

△ 7.1.2 Backlight

Item	Symbol	Condition	Rating			Unit	Applicable terminal
			MIN	TYP	MAX		
Forward current	IL1	Ta=25°C	--	18.0	32.0	mA	BLH - BLL1
	IL2	Note1	--	18.0	32.0	mA	BLH - BLL2
Forward voltage *Reference value	VF1	Ta=25°C	7.47	7.90	8.49	V	BLH - BLL1
	VF2	IL1=IL2=18.0mA	7.47	7.90	8.49	V	BLH - BLL2
Estimated Life of LED	LL	Ta=25°C IL1=IL2=18.0mA,Note2	--	50,000	--	hrs	

Note1: - Please control so that each current does not vary (IL1 = IL2).

Note2: - The lifetime of the LED is defined as a period till the brightness of the LED decreases to the half of its initial value.

- This figure is given as a reference purpose only, and not as a guarantee.
- This figure is estimated for an LED operating alone.

As the performance of an LED may differ when assembled as a monitor together with a TFT panel due to different environmental temperature.

- Estimated lifetime could vary on a different temperature and usually higher temperature could reduce the life significantly.

△ 7.2 AC Characteristics

(Unless otherwise noted, Ta=25°C, VDD=3.3V, VSS=0V)

Item	Symbol	Condition	Rating			Unit	Applicable terminal
			MIN	TYP	MAX		
CLK frequency	fCLK		5.5	5.6	8.8	MHz	CLK
CLK rising time	tr		--	--	10	ns	
CLK falling time	tf		--	--	10	ns	
CLK Low period	tw1L	0.3×VDD or less.	26.4	--	--	ns	
CLK High period	tw1H	0.7×VDD or more.	26.4	--	--	ns	
Setup time	tsp		10.0	--	--	ns	CLK,VSYNC,HSYNC, DE,D[27:20],D[17:10], D[07:00]
Hold time	thd		16.0	--	--	ns	

Switching Waveform Characteristics

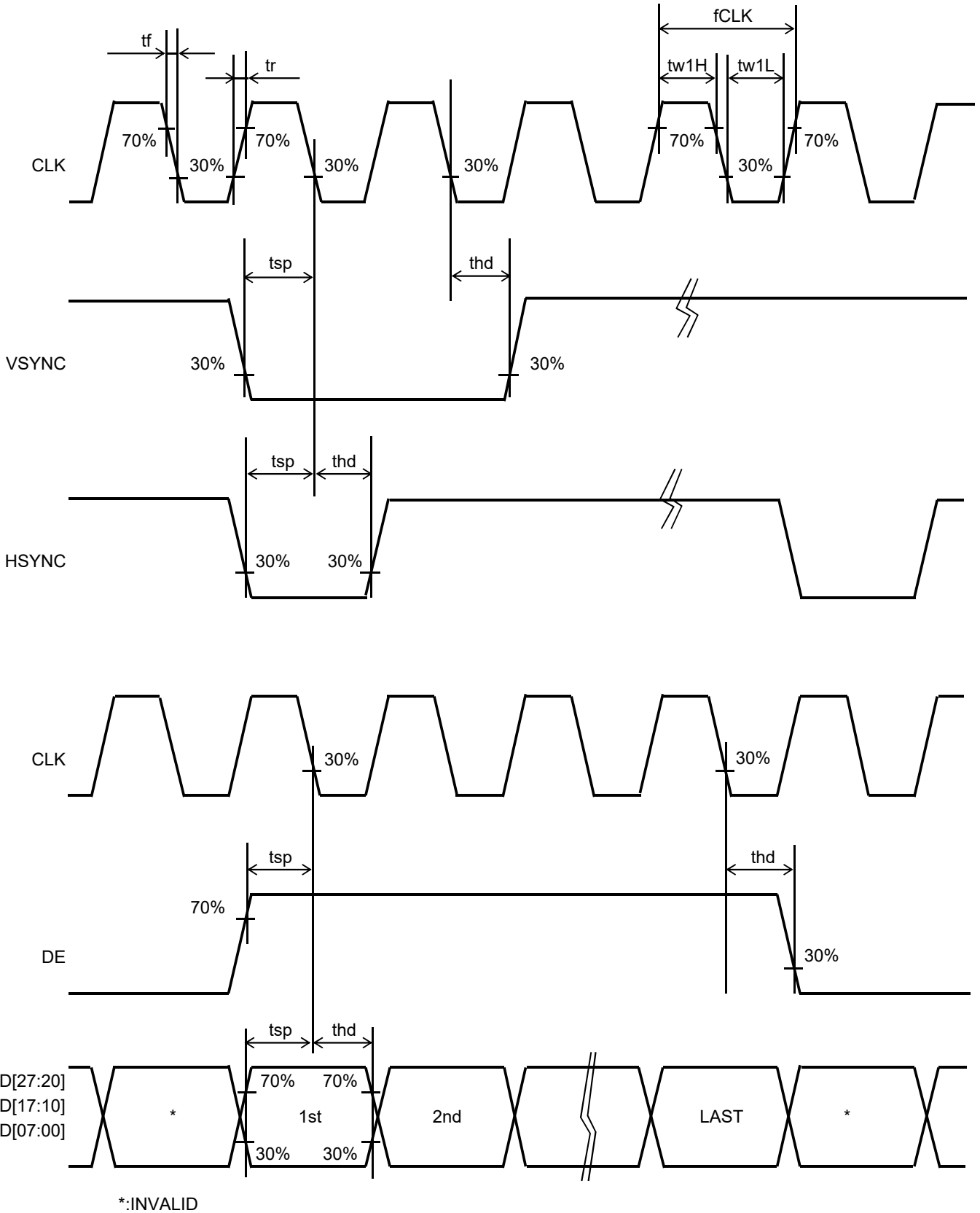

7.3 Input Timing Characteristics

(Unless otherwise noted, Ta=25°C, VDD=3.3V, VSS=0V)

Item	Symbol	Rating			Unit	Applicable terminal
		MIN	TYP	MAX		
CLK frequency	fCLK	5.5	5.6	8.8	MHz	CLK
VSYNC frequency	Note fVSYNC	54	60	66	Hz	VSYNC
VSYNC signal cycle time	tv	245	256	364	H	VSYNC,HSYNC
VSYNC pulse width	tw2H	1	--	--	H	
Vertical back porch	tvb	tw2H + 2	8	31	H	
Vertical front porch	tvf	2	8	93	H	
Vertical display period	tvdp	240			H	VSYNC,HSYNC,DE,D[27:20], D[17:10],D[07:00]
HSYNC frequency	fHSYNC	15.36			Khz	HSYNC
HSYNC signal cycle time	th	359	365	574	CLK	HSYNC,CLK
HSYNC pulse width	tw3H	1	--	--	CLK	
Horizontal back porch	thb	tw3H + 1	40	127	CLK	HSYNC,DE,CLK
Horizontal front porch	thf	1	5	127	CLK	
Horizontal display period	thdp	320			CLK	DE,D[27:20],D[17:10],D[07:00], CLK
DE pulse width	tw4H	320			CLK	DE,CLK

Note: The characteristics and values in the chart indicate recommended specifications.

In the case that the product might be used NOT in compliant with the specifications, it is highly recommended to use the product after adequate verifications could be implemented and at your own risk.

7.4 Driving Timing Chart

-Vertical Timing

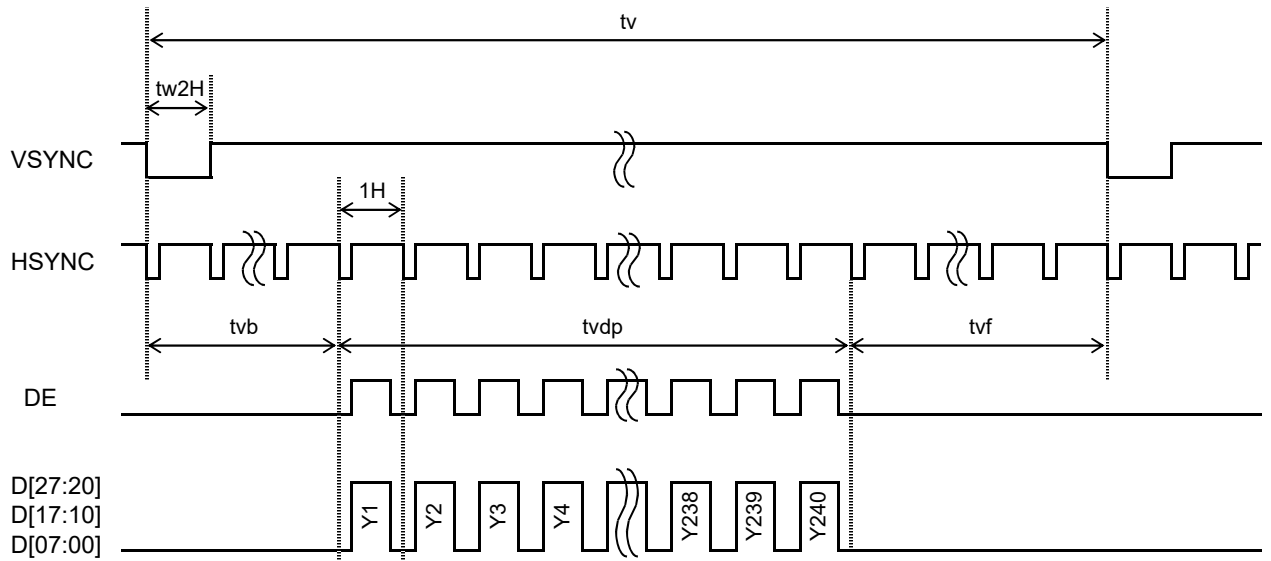

-Horizontal Timing

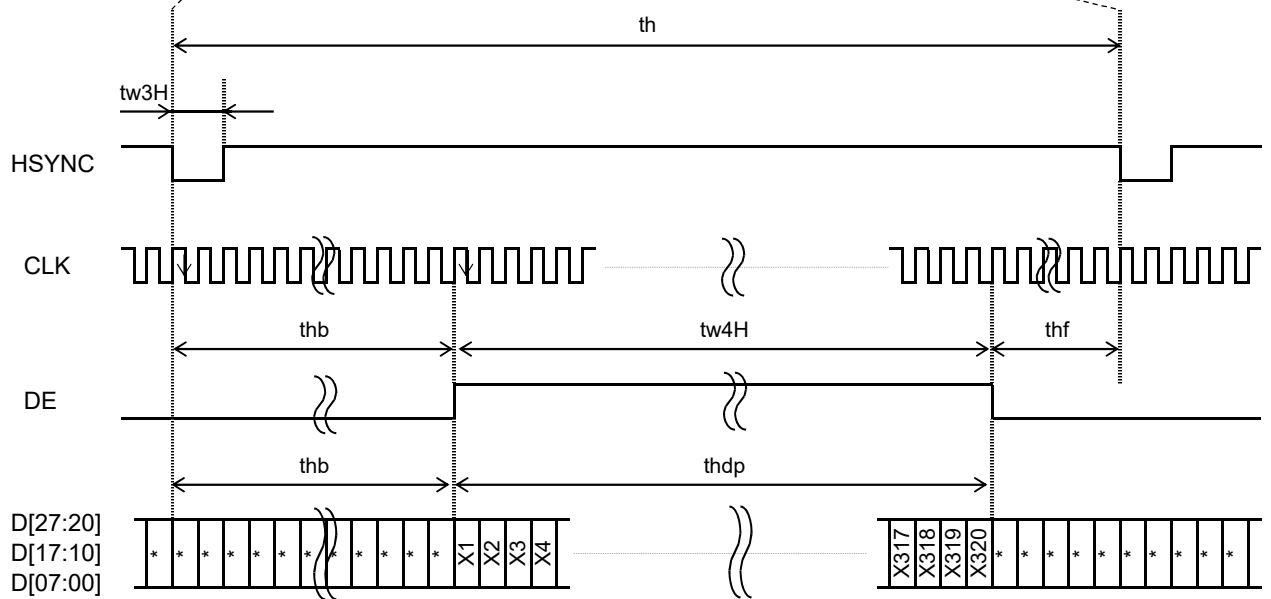

7.5 Example of Driving Timing Chart (fCLK=5.6MHz)

-Vertical Timing

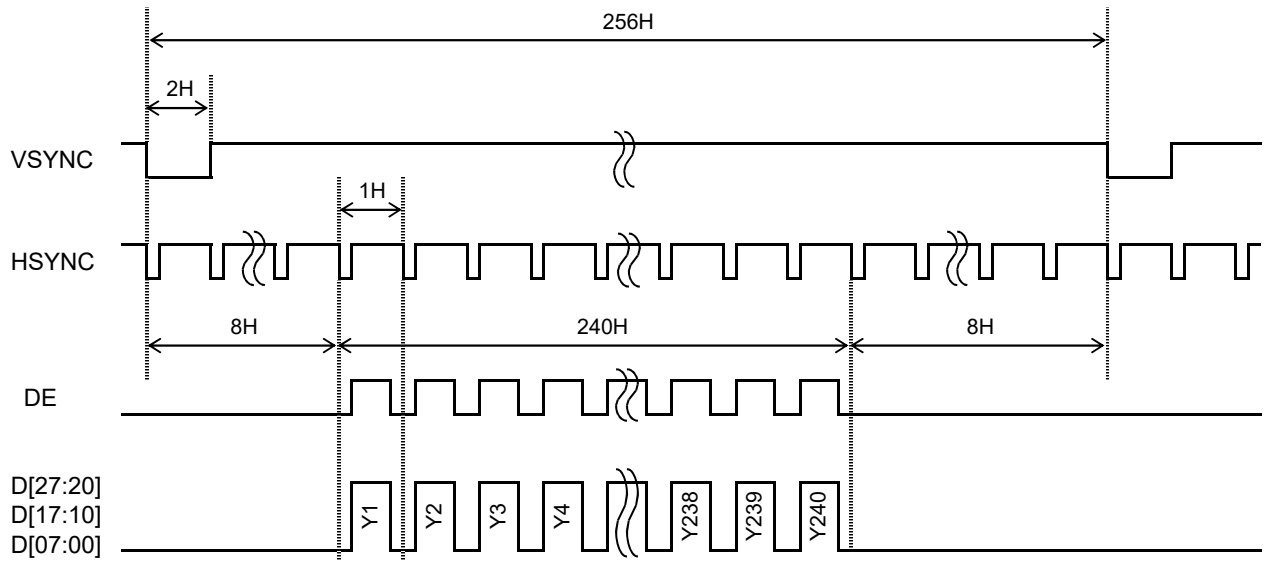

-Horizontal Timing

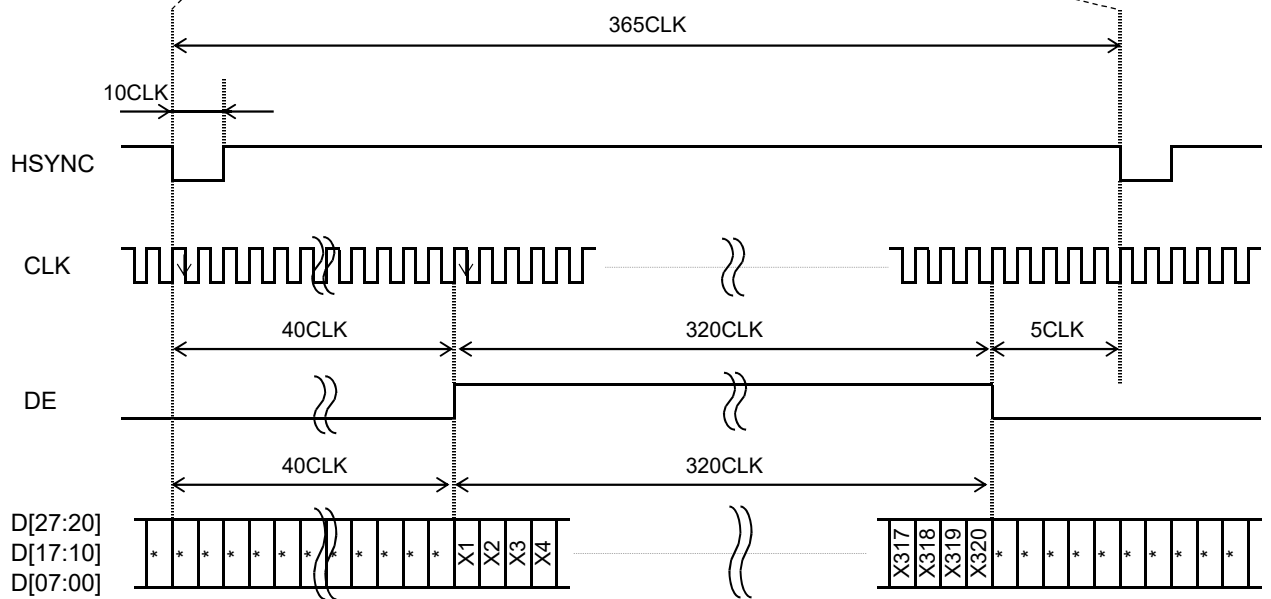

8. Power ON/OFF Sequence

8.1 Power ON Sequence

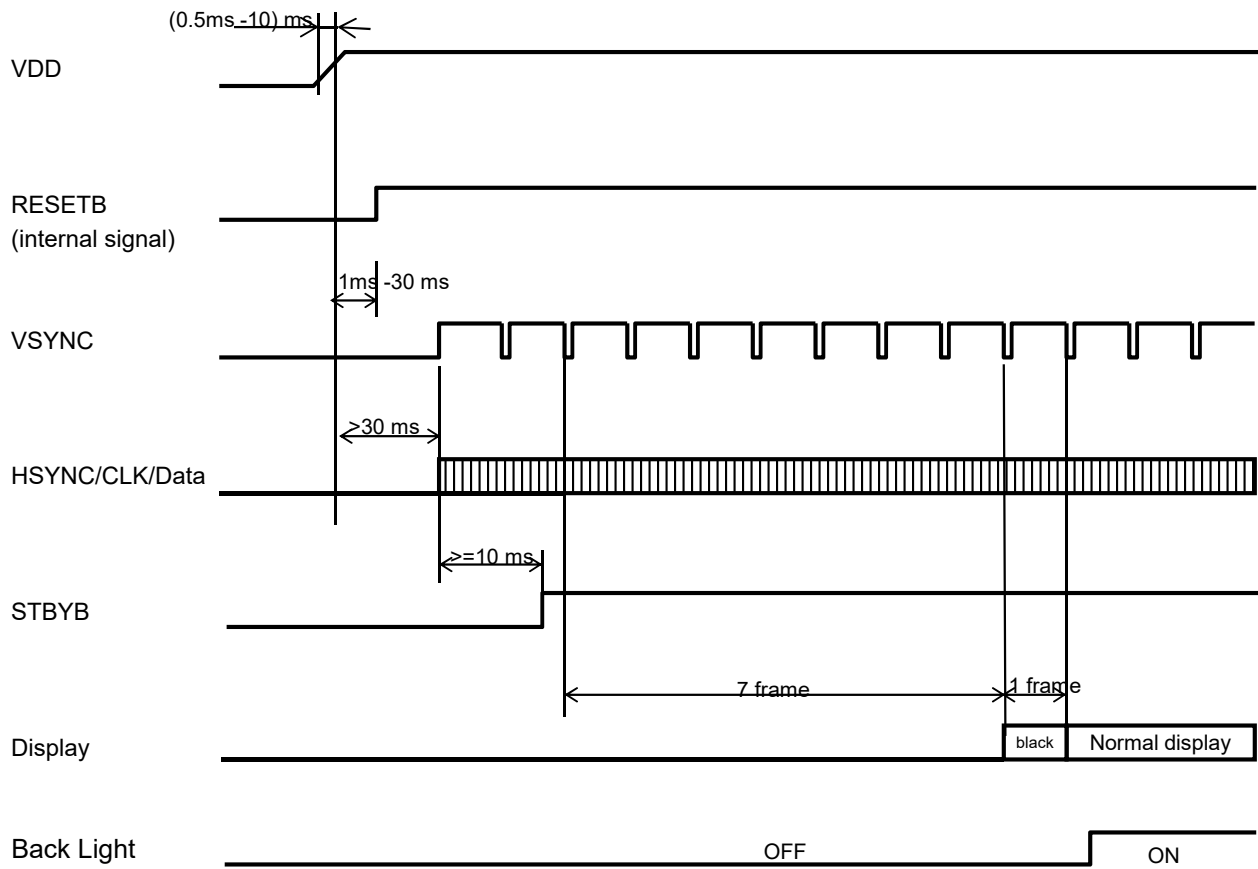

8.2 Standby / Power OFF Sequence

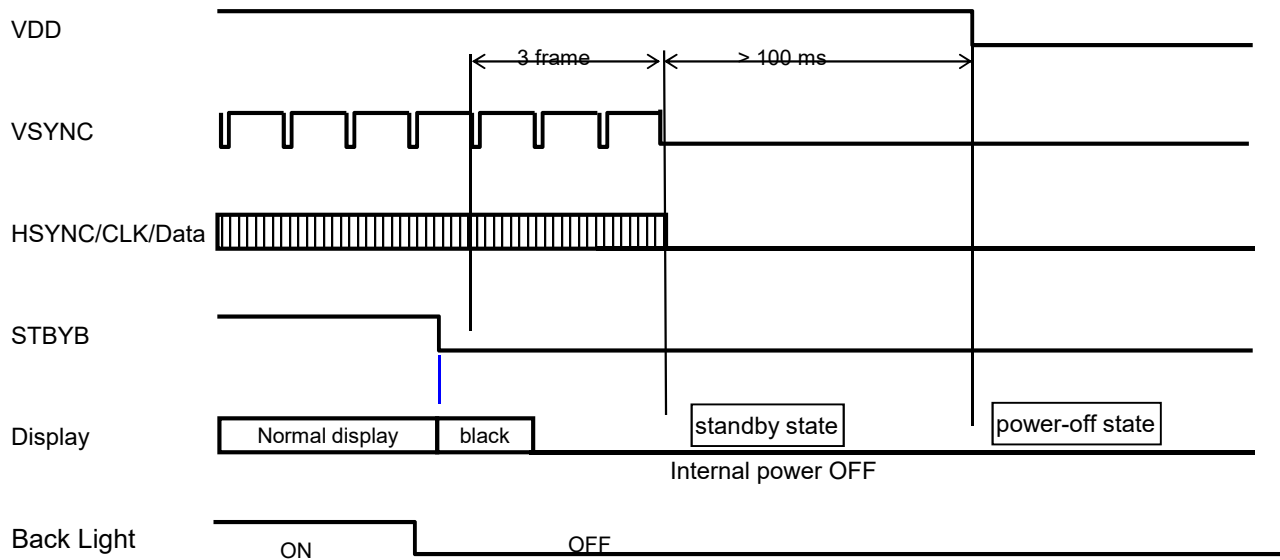

If CLK and VSYNC signals are stopped or the power supply is turned off to a regulated frame or less, the afterimage might remain.

9. LED Circuit

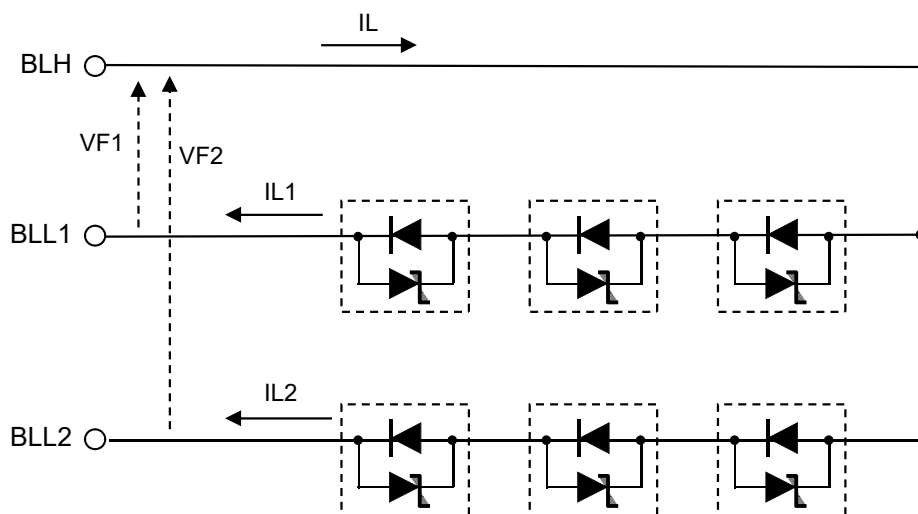

* It is recommended to control currents of BLL1 / BLL2 to equal current values ($I_{L1} = I_{L2}$).

10. Characteristics

 10.1 Optical Characteristics

< Measurement Condition >

Measuring instruments: CS2000 (KONICA MINOLTA), LCD7200(OTSUKA ELECTRONICS),EZcontrastXL88 (ELDIM)

Driving condition: VDD=3.3V,GND=0V

Optimized VCOMDC

Backlight: IL1=IL2=18.0mA

Measured temperature: Ta=25° C

Item		Symbol	Condition	MIN	TYP	MAX	Unit	Note No.	Remark
Response time	Rise time +	TON	[Data]= 00h→FFh→00h	—	—	100	ms	1	
	Fall time	TOFF							
Contrast ratio	Backlight ON	CR	[Data]= FFh / 00h	350	700	—		2	
	Backlight OFF			—	2.0	—			
Viewing angle	Left	θL	[Data]= FFh / 00h CR ≥ 10	80	—	—	deg	3	
	Right	θR		80	—	—	deg		
	Up	φU		80	—	—	deg		
	Down	φD		80	—	—	deg		
White Chromaticity		x	[Data]=FFh	White chromaticity range				4	
		y							
Burn-in				No noticeable burn-in image should be observed after 2 hours of window pattern display.				5	
Center brightness			[Data]=FFh	400	600	—	cd/m ²	6	
Brightness distribution			[Data]=FFh	70	—	—	%	7	

* Note number 1 to 7: Refer to the APPENDIX of "Reference Method for Measuring Optical Characteristics".

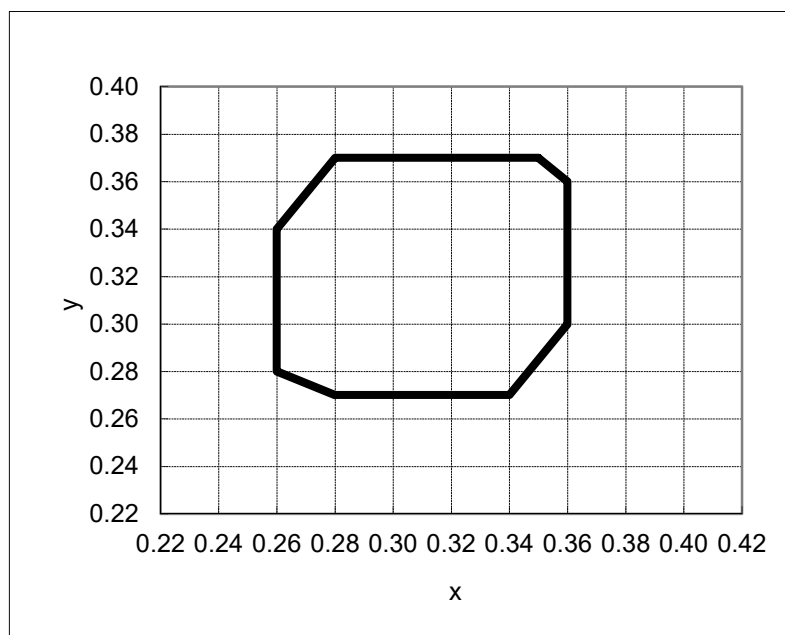

【White Chromaticity Range】

x	y
0.35	0.37
0.28	0.37
0.26	0.34
0.26	0.28
0.28	0.27
0.34	0.27
0.36	0.30
0.36	0.36

White Chromaticity Range



10.2 Temperature Characteristics

< Measurement Condition >

Measuring instruments: CS2000 (KONICA MINOLTA), LCD7200(OTSUKA ELECTRONICS)

Driving condition: VDD=3.3V,GND=0V

Optimized VCOMDC

Backlight: IL1=IL2=18.0mA

Item			Specification		Remark
			Ta=-30°C	Ta=85°C	
Contrast ratio		CR	200 or more	200 or more	Backlight ON
Response time	Rise time + Fall time	TON + TOFF	1500 ms or less	80 ms or less	
Display Quality			No noticeable display defect or nonuniformity should be observed.		

11. Criteria of Judgment

11.1 Defective Display and Screen Quality

Test Condition: Observed TFT-LCD monitor from front during operation with the following conditions

Driving Signal Raster Patter (RGB, white, black)

Signal condition [Data]: FFh, 94h, 00h (3steps)

Observation distance 30 cm

Illuminance 200 to 350 lx

Backlight IL1=IL2=18.0mA

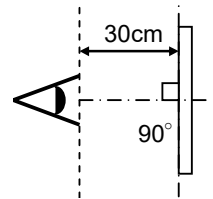

Defect item	Defect content	Criteria		
Display Quality	Line defect	Black, white or color line, 3 or more neighboring defective dots	Not exists	
	Dot defect	Uneven brightness on dot-by-dot base due to defective TFT or CF, or dust is counted as dot defect (brighter dot, darker dot)	Refer to table 1	
		High bright dot: Visible through 2% ND filter at [Data]=00h		
		Low bright dot: Visible through 5% ND filter at [Data]=00h		
Dark dot: Appear dark through white display at [Data]= 94h	ignored			
Screen Quality	Stain	Uneven brightness (white stain, black stain etc)	Invisible through 1% ND filter	
	Foreign particle	Point-like	$0.25\text{mm} < \varphi$	$N=0$
			$0.20\text{mm} < \varphi \leq 0.25\text{mm}$	$N \leq 2$
			$\varphi \leq 0.20\text{mm}$	Ignored
		Liner	$3.0\text{mm} < \text{length and } 0.08\text{mm} < \text{width}$	$N=0$
	$\text{length} \leq 3.0\text{mm}$ or $\text{width} \leq 0.08\text{mm}$		Ignored	
Others		Use boundary sample for judgment when necessary		

φ (mm): Average diameter = (major axis + minor axis)/2
Permissible number: N

Table 1

Area	High bright dot	Low bright dot	Dark dot	Total	Criteria
A	0	2	2	3	Permissible distance between same color bright dots (includes neighboring dots): 3 mm or more Permissible distance between same color high bright dots (includes neighboring dots): 5 mm or more
B	2	4	4	6	
Total	2	4	4	7	

<Landscape model>

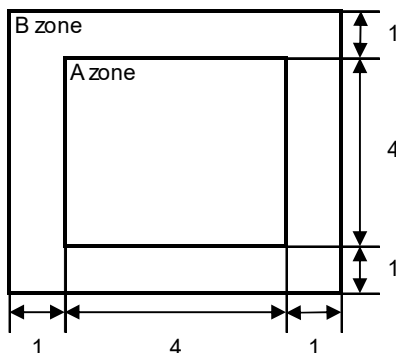

Division of A and B areas

B area: Active area

Dimensional ratio between A and B areas: 1: 4: 1 (Refer to the left figure)

11.2 Screen and Other Appearance

Testing conditions

Observation distance

30cm

Illuminance

1200~2000 lx

Item		Criteria	Remark
Polarizer	Flaw	Ignore invisible defect when the backlight is on.	Applicable area: Active area only (Refer to the section 3.2 "Outward form")
	Stain		
	Dirt		
	Bubble		
	Dust		
Dent			
S-case		No functional defect occurs	
FPC cable		No functional defect occurs	



12. Reliability Test

Test item		Test condition		number of failures / number of examinations
Durability test	High temperature storage	Ta=95°C	500hrs	0 / 3
	Low temperature storage	Ta=-40°C	500hrs	0 / 3
	High temperature & high humidity storage	Ta=60°C, RH=90% non condensing	500hrs	0 / 3
	High temperature operation	Tp=85°C	500hrs	0 / 3
	Low temperature operation	Tp=-30°C	500hrs	0 / 3
	High temperature & high humidity operation	Tp=40°C, RH=90% non condensing	500hrs	0 / 3
	Thermal shock storage	-40↔95°C(30min/30min) 100cycles		0 / 3
	Lightfastness	Xenon Blackpanel 63±3°C non-shower 450W/m ² (300~700nm) non-operating Integral dose 800MJ/m ²		0 / 3
Mechanical environmental test	Electrostatic discharge test (Non operation)	Confirms to EIAJ ED-4701/300 C=200pF,R=0Ω,V=±200V Each 3 times of discharge on and power supply and other terminals.		0 / 3
	Surface discharge test (Non operation)	C=250pF, R=100Ω, V=±12kV Each 5 times of discharge in both polarities on the center of screen with the case grounded.		0 / 3
	FPC tension test	Pull the FPC with the force of 3N for 10 sec. in the direction -90-degree to its original direction.		0 / 3
	FPC bend test	Pull the FPC with the force of 3N for 10 sec. in the direction -180-degree to its original direction. Reciprocate it 3 times.		0 / 3
	Vibration test	Total amplitude 1.5mm, f=10~55Hz, X,Y,Z directions for each 2 hours		0 / 3
	Impact test (Non operation)	Use TOPPAN PRINTING original jig (see next page) (see next page)and make an impact with peak acceleration of 1000m/s ² for 6 msec with half sine-curve at 3 times to each X, Y, Z directions in conformance with JIS C 60068-2-27-2011.		0 / 3
Packing test	Packing vibration -proof test	Acceleration of 19.6m/s ² with frequency of 10→55→10Hz, X,Y, Zdirection for each 30 minutes		0 / 1 packing
	Packing drop test	Drop from 75cm high. 1 time to each 6 surfaces, 3 edges, 1 corner		0 / 1 packing

Note:Ta=ambient temperature Tp=Panel temperature

※ The profile of high temperature/humidity storage and High Temperature/humidity operation
(Pure water of over 10MΩ·cm shall be used.)

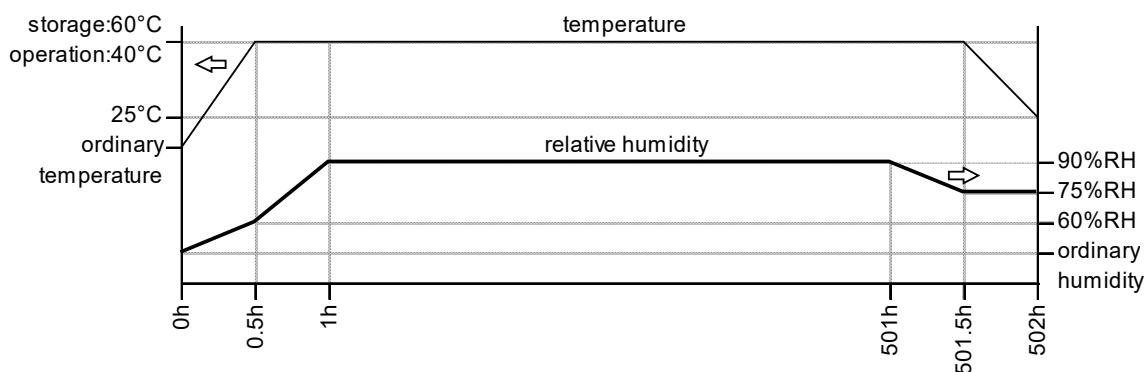
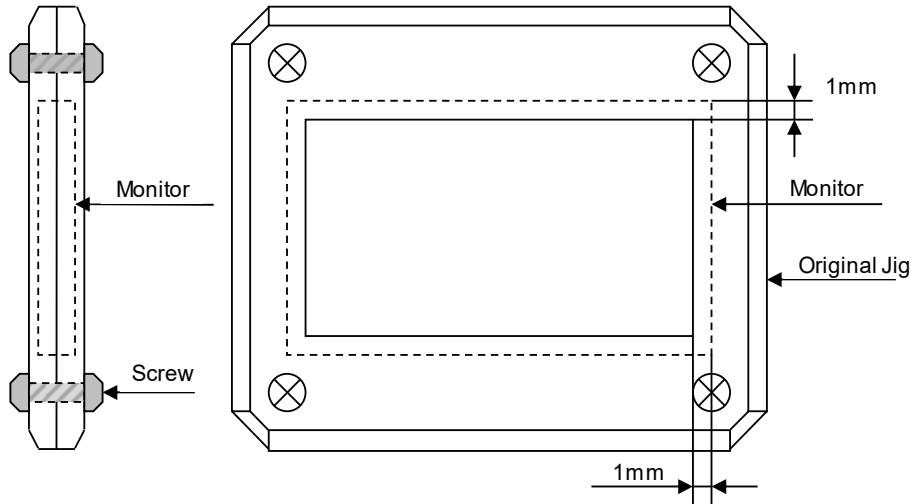

Table2.Reliability Criteria

The parameters should be measured after leaving the monitor at the ordinary temperature for 24 hours or more after the test completion.

item	Standard	Remarks
Display quality	No visible abnormality shall be seen. (Except for unevenness by PoI deterioration.)	
Contrast ratio	200 or more	Backlight ON

TOPPAN PRINTING Original Jig



Tension Test Method for FPC cable

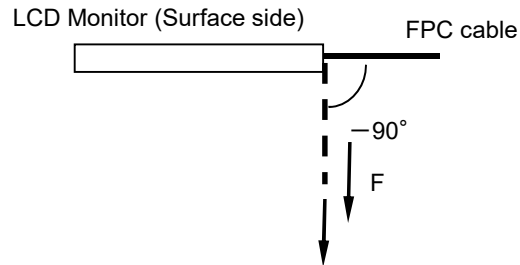

Bend Test Method for FPC cable

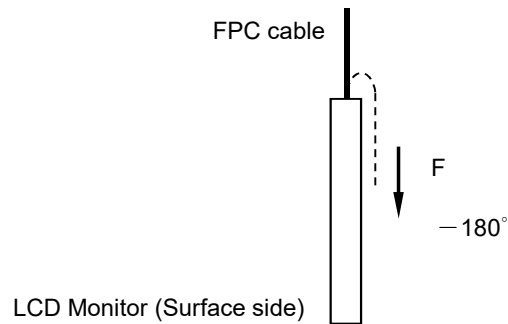



13. Packing Specifications

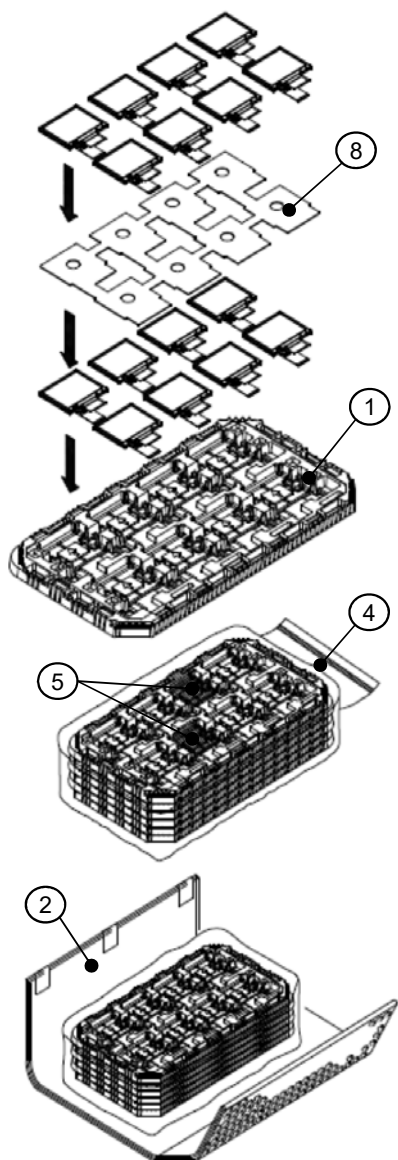

Step1. Each product is to be placed in one of the cut-outs of the tray with the display surface facing upward. (8 products per tray)
Foam sheet is to be placed on the products in the tray.
Each product is to be placed in one of the cut-outs of the tray with the display surface facing upward.(16 products per tray)

Step2. The trays be in a stack of 5.(Rotate 180 degrees for each step)
One empty tray is to be put on the top of stack of 5 trays.

Step3. 2 packs of moisture absorbers are to be placed on the top tray as shown in the drawing. Put piled trays into a sealing bag.

Step4. Vacuum and seal the sealing bag with the vacuum sealing machine.

Step5. The stack of trays in the sealing bag is to be wrapped with a bubble cushioning sheet.

Step6. The wrapped trays are placed in the outer carton.

Step7. Bubble cushioning sheets are to be inserted into the outer carton with same orientation. The outer carton is to be sealed in H-shape with packing tape as shown in the drawing.

Step8. The model number, quantity of products, and shipping date are to be printed on the outer carton.
If necessary, shipping labels or impression markings are to be put on the outer carton.

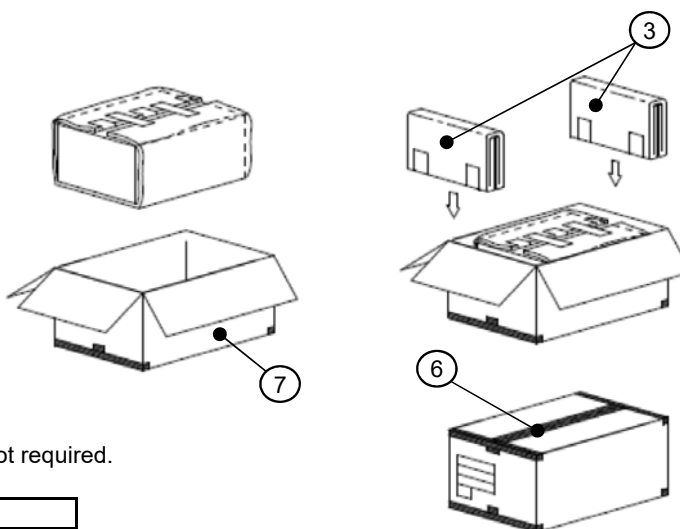

Remark: The return of packing materials is not required.

Packing item name	Specs., Material
① Tray	A-PET
② B SHEET C	Antistatic air bubble sheet
③ B SHEET D	Antistatic air bubble sheet
④ Sealing bag	
⑤ Drier	Moisture absorber
⑥ Packing tape	
⑦ Outer carton	Corrugated cardboard
⑧ Foam sheet	Anti-static polyethylene

Dimension of outer carton	
D : Approx.	(356mm)
W : Approx.	(664mm)
H : Approx.	(182mm)
Quantity of products packed in one carton:	80
Gross weight : Approx.	5.4 kg

TOPPAN PRINTING CO.,LTD.

14. Handling Instruction

14.1 Cautions for Handling LCD panels

**Caution**

- (1) Do not make an impact on the LCD panel glass because it may break and you may get injured from it.
- (2) If the glass breaks, do not touch it with bare hands.
(Fragment of broken glass may stick you or you cut yourself on it.)
- (3) If you get injured, receive adequate first aid and consult a medial doctor.
- (4) Do not let liquid crystal get into your mouth.
(If the LCD panel glass breaks, try not let liquid crystal get into your mouth even toxic property of liquid crystal has not been confirmed.)
- (5) If liquid crystal adheres, rinse it out thoroughly.
(If liquid crystal adheres to your cloth or skin, wipe it off with rubbing alcohol or wash it thoroughly with soap. If liquid crystal gets into eyes, rinse it with clean water for at least 15 minutes and consult an eye doctor.)
- (6) If you scrap this products, follow a disposal standard of industrial waste that is legally valid in the community, country or territory where you reside.
- (7) Do not connect or disconnect this product while its application products is powered on.
- (8) Do not attempt to disassemble or modify this product as it is precision component.
- (9) If a part of soldering part has been exposed, and avoid contact (short-circuit) with a metallic part of the case etc. about FPC of this model, please.
Please insulate it with the insulating tape etc. if necessary.
The defective operation is caused, and there is a possibility to generation of heat and the ignition.
- (10) Since excess current protection circuit is not built in this TFT module, there is the possibility that LCD module or peripheral circuit become feverish and burned in case abnormal operation is generated.
We recommend you to add excess current protection circuit to power supply.
- (11) The devices on the FPC are damageable to electrostatic discharge, because the terminals of the devices are exposed.
Wear grounded wrist-straps and use electrostatic neutralization blowers to prevent static charge and discharge when handling the TFT monitors.
Designate an appropriate operating area, and set equipment, tools, and machines properly when handling this product.

Caution This mark is used to indicate a precaution or an instruction which, if not correctly observed, may result in bodily injury, or material damages alone.

14.2 Precautions for Handling

- 1) Wear finger tips at incoming inspection and for handling the TFT monitors to keep display quality and keep the working area clean.
Do not touch the surface of the monitor as it is easily scratched.
- 2) Wear grounded wrist-straps and use electrostatic neutralization blowers to prevent static charge and discharge when handling the TFT monitors as the LED in this TFT monitors is damageable to electrostatic discharge. Designate an appropriate operating area, and set equipment, tools, and machines properly when handling this product.
- 3) Avoid strong mechanical shock including knocking, hitting or dropping to the TFT monitors for protecting their glass parts. Do not use the TFT monitors that have been experienced dropping or strong mechanical shock.
- 4) Do not use or storage the TFT monitors at high temperature and high humidity environment. Particularly, never use or storage the TFT monitors at a location where condensation builds up.
- 5) Avoid using and storing TFT monitors at a location where they are exposed to direct sunlight or ultraviolet rays to prevent the LCD panels from deterioration by ultraviolet rays.
- 6) Do not stain or damage the contacts of the FPC cable .
FPC cable needs to be inserted until it can reach to the end of connector slot.
During insertion, make sure to keep the cable in a horizontal position to avoid an oblique insertion.
Otherwise, it may cause poor contact or deteriorate reliability of the FPC cable.
- 7) Do not bend or pull the FPC cable or carry the TFT monitor by holding the FPC cable.
Especially, it will cause mechanical damage or critical defect if FPC is pull up or bent up to short of display.

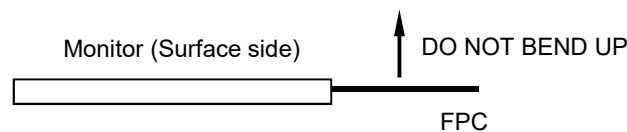

- 8) Peel off the protective film on the TFT monitors during mounting process.
Refer to the section 14.5 on how to peel off the protective film.
We are not responsible for electrostatic discharge failures or other defects occur when peeling off the protective film.
- 9) Please make it to the structure to suppress surroundings of the front polarizer for the display irregularity prevention.

14.3 Precautions for Operation

- 1) Since this TFT monitors are not equipped with light shielding for the driver IC, do not expose the driver IC to strong lights during operation as it may cause functional failures.
- 2) In case of powering up or powering off this LCD module, be sure to comply the sequence as instructed in this specification.
- 3) Do not plug in or out the FPC cable while power supply is switch on.
Plug the FPC cable in and out while power supply is switched off.
- 4) Do not operate the TFT monitors in the strong magnetic field. It may break the TFT monitors.
- 5) Do not display a fixed image on the screen for a long time.
Use a screen-saver or other measures to avoid a fixed image displayed on the screen for a long time.
Otherwise, it may cause burn-in image on the screen due the characteristics of liquid crystal.

14.4 Storage Condition for Shipping Cartons

Storage environment

- Temperature 0 to 40° C
- Humidity 60%RH or less
No-condensing occurs under low temperature with high humidity condition.
- Atmosphere No poisonous gas that can erode electronic components and/or wiring materials should be detected.
- Time period 1 year
- Unpacking To prevent damages caused by static electricity, anti-static precautionary measures (e.g. earthing, anti-static mat) should be implemented.
- Maximum piling up 7 cartons

*Conditions to storage after unpacking

Storage environment

- Temperature 0 to 40° C
- Humidity 60%RH or less
No-condensing occurs under low temperature with high humidity condition.
- Atmosphere No poisonous gas that can erode electronic components and/or wiring materials should be detected.
- Time period 1 year (Shelf life)
- Others Keep/ store away from direct sunlight
Storage goods on original tray made by TOPPAN PRINTING.

△ 14.5 Precautions for Peeling off the Protective film

The followings work environment and work method are recommended to prevent the TFT monitors from static damage or adhesion of dust when peeling off the protective films.

A) Work Environment

- a) Humidity: 50 to 70 %RH, Temperature 15 to 27° C
- b) Operators should wear conductive shoes, conductive clothes, conductive finger tips and grounded wrist-straps. Anti-static treatment should be implemented to work area's floor.
- c) Use a room shielded against outside dust with sticky floor mat laid at the entrance to eliminate dirt.

B) Work Method

The following procedures should taken to prevent the driver ICs from charging and discharging.

- a) Use an electrostatic neutralization blower to blow air on the TFT monitors to its lower left when FPC is placed at the bottom.

Optimize direction of the blowing air and the distance between the TFT monitors and the electrostatic neutralization blower.

- b) Put an adhesive tape (Scotch tape, etc) at the lower left corner area of the protective film to prevent scratch on surface of TFT monitors.
- c) Peel off the adhesive tape slowly (spending more than 2 secs to complete) by pulling it to opposite direction.

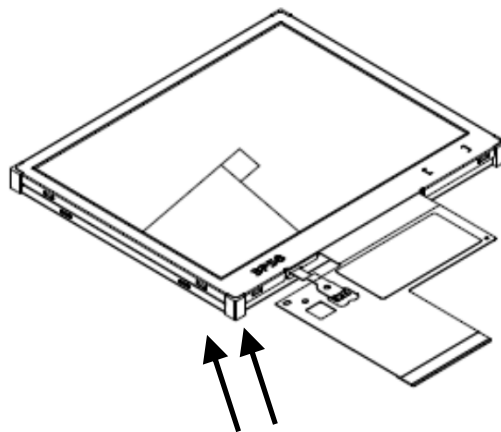

Direction of blowing air
(Optimize air direction and the distance)

14.6 Warranty

TOPPAN PRINTING is only liable to defective goods which is stored and used under the condition complying with this specifications and returned within 1 (one) year.

Warranty caused by manufacturing defect shall be conducted by replacement of goods or refundment at unit price.

APPENDIX

Reference Method for Measuring Optical Characteristics and Performance

1. Measurement Condition (Backlight ON)

Measuring instruments: CS2000 (KONICA MINOLTA) , LCD7200(OTSUKA ELECTRONICS) ,EZcontrastXL88 (ELDIM)

Driving condition: Refer to the section "Optical Characteristics"

Measured temperature: 25° C unless specified

Measurement system: See the chart below. The luminance meter is placed on the normal line of measurement system.

Measurement point: At the center of the screen unless otherwise specified

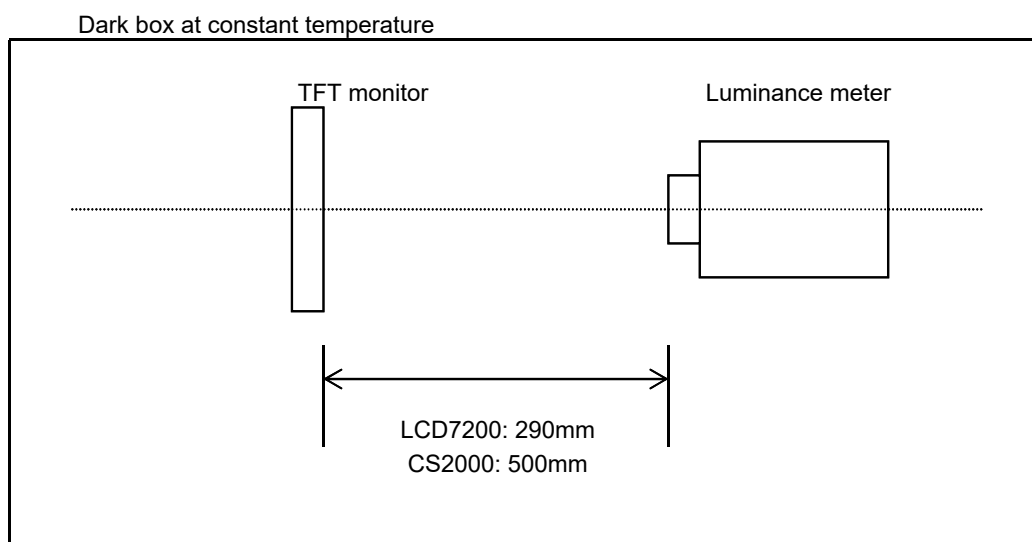

Measurement is made after 30 minutes of lighting of the backlight.

Measurement point: At the center point of the screen

Brightness distribution: 9 points shown in the following drawing.

<Landscape model>

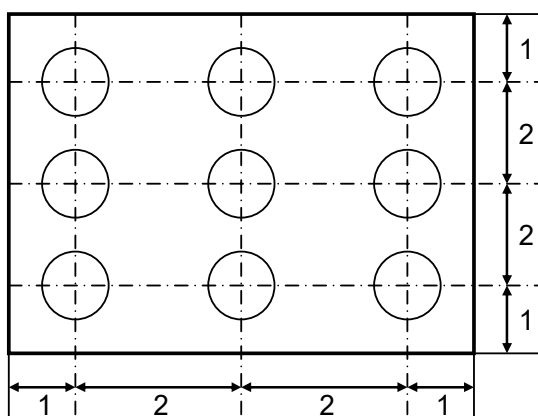

Dimensional ratio of active area

Backlight IL1=IL2=18.0mA

Measurement Condition (Contrast ratio Backlight OFF only)

- Measuring instruments: LCD7200(OTSUKA ELECTRONICS),Ring Light(40,000 lx, ϕ 58)
- Driving condition: Refer to the section "Optical Characteristics"
- Measured temperature: 25°C unless specified
- Measurement system: See the chart below.
- Measurement point: At the center of the screen.

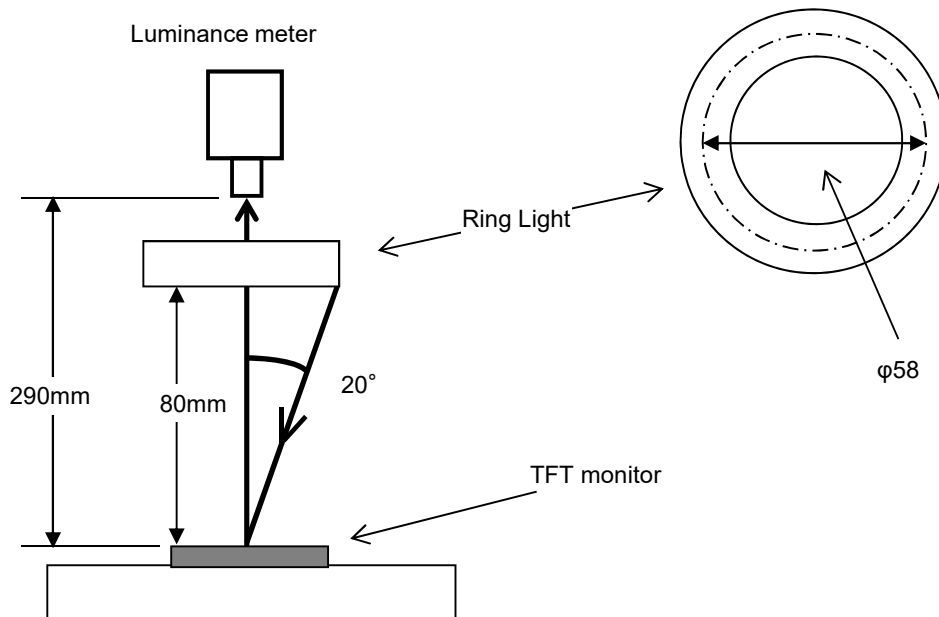

2. Test Method

Notice	Item	Test method	Measuring instrument	Remark
1	Response time	<p>Measure output signal waveform by the luminance meter when raster of window pattern is changed from white to black and from black to white.</p> <p style="text-align: center;">Black White Black</p> <p>White brightness</p> <p>100%</p> <p>90%</p> <p>10%</p> <p>0%</p> <p>Black brightness</p> <p>TON</p> <p>TOFF</p>	LCD7200	Black display [Data]=00h White display [Data]=FFh TON Rise time TOFF Fall time
2	Contrast ratio	<p>Measure maximum luminance Y1([Data]=FFh) and minimum luminance Y2([Data]=00h) at the center of the screen by displaying raster or window pattern. Then calculate the ratio between these two values.</p> <p style="text-align: center;">Contrast ratio = Y1/Y2</p> <p style="text-align: center;">Diameter of measuring point: 7.8mmφ(CS2000)</p> <p style="text-align: center;">Diameter of measuring point: 3mmφ(LCD7200)</p>	CS2000 LCD7200	Backlight ON Backlight OFF
3	Viewing angle Horizontalθ Verticalφ	Move the luminance meter from right to left and up and down and determine the angles where contrast ratio is 10.	EZcontrastXL88	
4	White chromaticity	<p>Measure chromaticity coordinates x and y of CIE1931 colorimetric system at [Data] = FFh</p> <p style="text-align: center;">Color matching function: 2°view</p> <p style="text-align: center;">Measurement angle: 1°</p>	CS2000	
5	Burn-in	Visually check burn-in image on the screen after 2 hours of "window display" ([Data]=FFh/00h).		At optimized VCOMDC
6	Center brightness	Measure the brightness at the center of the screen.	CS2000	
7	Brightness distribution	<p>(Brightness distribution) = 100 x B/A %</p> <p>A : max. brightness of the 9 points</p> <p>B : min. brightness of the 9 points</p>	CS2000	

Our company network supports you worldwide with offices in Germany, Austria, Switzerland, the UK and the USA. For more information please contact:

Headquarters

Germany



FORTEC Elektronik AG

Augsburger Str. 2b
82110 Germering

Phone: +49 89 894450-0
E-Mail: info@fortecaq.de
Internet: www.fortecaq.de

Fortec Group Members

Austria



Distec GmbH Office Vienna

Nuschingasse 12
1230 Wien

Phone: +43 1 8673492-0
E-Mail: info@distec.de
Internet: www.distec.de

Germany



Distec GmbH

Augsburger Str. 2b
82110 Germering

Phone: +49 89 894363-0
E-Mail: info@distec.de
Internet: www.distec.de

Switzerland



ALTRAC AG

Bahnhofstraße 3
5436 Würenlos

Phone: +41 44 7446111
E-Mail: info@altrac.ch
Internet: www.altrac.ch

United Kingdom



Display Technology Ltd.

Osprey House, 1 Osprey Court
Hinchingsbrooke Business Park
Huntingdon, Cambridgeshire, PE29 6FN

Phone: +44 1480 411600
E-Mail: info@displaytechnology.co.uk
Internet: www.displaytechnology.co.uk

USA



Apollo Display Technologies, Corp.

87 Raynor Avenue, Unit 1
Ronkonkoma, NY 11779

Phone: +1 631 5804360
E-Mail: info@apolloDisplays.com
Internet: www.apolloDisplays.com