



OUR GLOBAL
COMPETENCE
CENTRES

 APOLLO DISPLAY
TECHNOLOGIES



 DISTEC



 DISPLAY
TECHNOLOGY



Datasheet

Ortustech

COM24H2P71ULC

Specifications for

Blanview TFT-LCD Monitor (2.4" QVGA 240 x RGB x 320 Portrait)

Version 1.0

(Please be sure to check the specifications latest version.)

MODEL COM24H2P71ULC

Customer's Approval

Signature:

Name:

Section:

Title:

Date:

ORTUSTECH

TOPPAN PRINTING CO.,LTD.
Electronics Division
Ortus Subdivision

Approved by

Y. Nakajima

Checked by

S. Kawayama

Prepared by

M. Shibamoto

Revision History

Ver.	Date	Page	Description
0.1	Jul.5,2019	-	- Tentative issue
1.0	Feb.5.2020		First issue
△ A ×10		3	change Change number of pages
		12	add Operating Current
		20	add White Chromaticity Range
			change Response time
		21	add Signal condision
		23	add Reliability Test
		25	add Packing Specifications
		26	add Add item
	27	add Add item	
	28	add Add page	

Contents

1. Application	4
2. Outline Specifications		
2.1 Features of the Product	5
2.2 Display Method	5
3. Dimensions and Shape		
3.1 Dimensions	7
3.2 Outward form	8
3.3 Serial No. print (S-print)	9
4. Pin Assignment	10
5. Absolute Maximum Rating	11
6. Recommended Operating Conditions	11
7. Electrical Characteristics		
7.1 DC Characteristics	12
7.2 AC Characteristics	13
8. Switching Waveform Characteristics	14
9. Input Timing		
9.1 Input Timing Characteristics	15
9.2 Input Timing Chart	16
10. Power ON/OFF sequence	17
11. LED Circuit	18
12. Characteristics		
12.1 Optical Characteristics	19
12.2 Temperature Characteristics	20
13. Criteria of Judgment		
13.1 Defective Display and Screen Quality	21
13.2 Screen and Other Appearance	22
14. Reliability Test	23
15. Packing Specifications	25
16. Handling Instruction		
16.1 Cautions for Handling LCD panels	26
16.2 Precautions for Handling	27
16.3 Precautions for Operation	27
16.4 Storage Condition for Shipping Cartons	28
16.5 Precautions for Peeling off the Protective film	29
16.6 Warranty	29
APPENDIX	30



1. Application

This Specification is applicable to 60.0mm (2.4 inch) Blanview TFT-LCD monitor for non-military use.

- ◎ TOPPAN PRINTING makes no warranty or assume no liability that use of this Product and/or any information including drawings in this Specification by Purchaser is not infringing any patent or other intellectual property rights owned by third parties, and TOPPAN PRINTING shall not grant to Purchaser any right to use any patent or other intellectual property rights owned by third parties. Since this Specification contains TOPPAN PRINTING's confidential information and copy right, Purchaser shall use them with high degree of care to prevent any unauthorized use, disclosure, duplication, publication or dissemination of TOPPAN PRINTING's confidential information and copy right.
- ◎ If Purchaser intends to use this Products for an application which requires higher level of reliability and/or safety in functionality and/or accuracy such as transport equipment (aircraft, train, automobile, etc.), disaster-prevention/security equipment or various safety equipment, Purchaser shall consult TOPPAN PRINTING on such use in advance.
- ◎ This Product shall not be used for application which requires extremely higher level of reliability and/or safety such as aerospace equipment, telecommunication equipment for trunk lines, control equipment for nuclear facilities or life-support medical equipment.
- ◎ It must be noted as an mechanical design manner, especial attention in housing design to prevent arcuation/flexure or caused by stress to the LCD module shall be considered.
- ◎ TOPPAN PRINTING assumes no liability for any damage resulting from misuse, abuse, and/or miss-operation of the Product deviating from the operating conditions and precautions described in the Specification.
- ◎ TOPPAN PRINTING is not responsible for any nonconformities and defects that are not specified in this specifications.
- ◎ If any issue arises as to information provided in this Specification or any other information, TOPPAN PRINTING and Purchaser shall discuss them in good faith and seek solution.
- ◎ TOPPAN PRINTING assumes no liability for defects such as electrostatic discharge failure occurred during peeling off the protective film or Purchaser's assembly process.
- ◎ This Product is compatible for RoHS(2.0) directive.

Object substance	Maximum content [ppm]
Cadmium and its compound	100
Hexavalent Chromium Compound	1000
Lead & Lead compound	1000
Mercury & Mercury compound	1000
Polybrominated biphenyl series (PBB series)	1000
Polybrominated biphenyl ether series (PBDE series)	1000
Bis(2-ethylhexyl)phthalate series(DEHP series)	1000
Butyl benzyl phthalate series(BBP series)	1000
Dibutyl phthalate series(DBP series)	1000
Diisobutyl phthalate series(DIBP series)	1000

2. Outline Specifications

2.1 Features of the Product

- 2.4" diagonal with resolution of 720[H]x320[V] dots. 240RGB x 320 pixel.
- 6-bit 262,144 color display capability.
- Single power supply operation of 3.3V.
- Timing generator [TG], Counter-electrode driving circuitry, Built-in power supply circuit.
- Long life & High bright white LED back-light.
- Blanview TFT-LCD, improved outdoor readability.

	Indoor		Outdoor	
	Readability	Power Efficiency (Battery Life)	Readability	Power Efficiency (Battery Life)
Transmissive	Good	Good	Fair	Poor
Transflective	Fair	Poor	Good	Good
Blanview	Good	Good	Good	Good

2.2 Display Method

Items	Specifications	Remarks
Display type	VA type 262,144 Colors. Blanview, Normally Black.	
Driving method	a-Si TFT Active matrix Line-scanning, Non-interlace	
Dot arrangement	RGB stripe arrangement	Refer to Fig. 1
Input signal type	6-bit RGB, parallel input.	
Backlight	Long life & High bright white LED.	
NTSC ratio	50%	

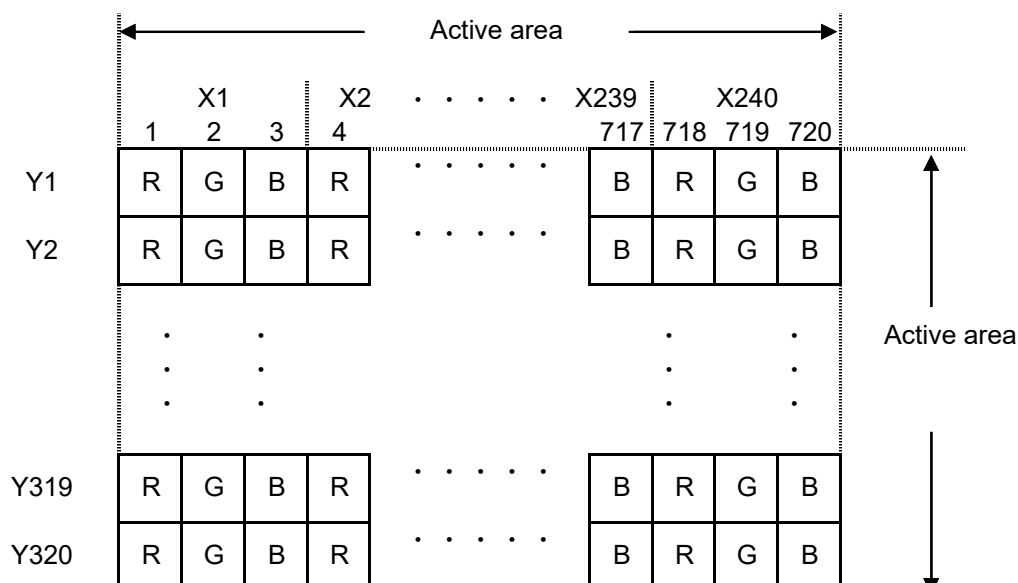
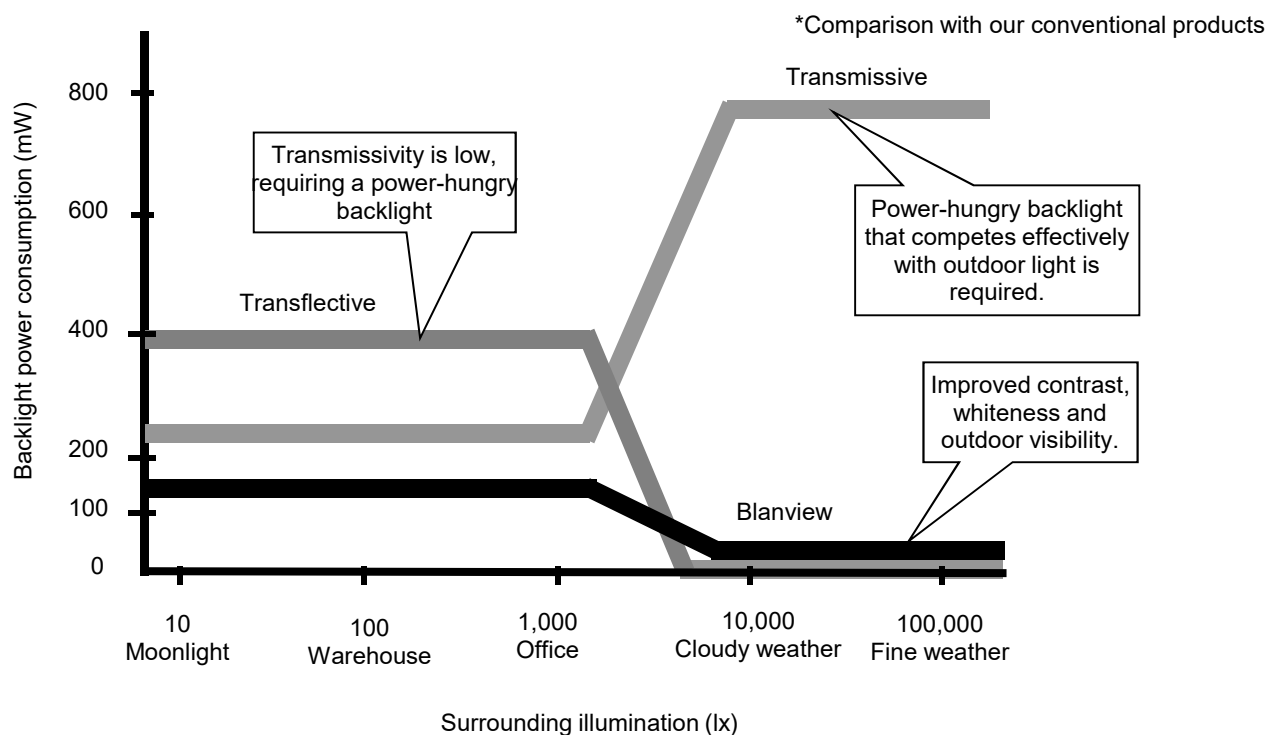

Fig. 1: Dot arrangement
(FPC cable placed left)

<Features of Blanview>

- Backlight power consumption required to assure visibility. (equivalent to 3.5"QVGA)



- Contrast characteristics under 100,000lx. (same condition as direct sunlight.)

With better contrast (higher contrast ratio), Blanview TFT-LCD has the best outdoor readability in three different types of TFT-LCD.

Below chart shows contrast value against panel surface brightness. (Horizontal: Panel surface brightness/ Vertical: Contrast value) LCD panel has enough outdoor readability above our Standard line. (TOPPAN PRINTING criteria)

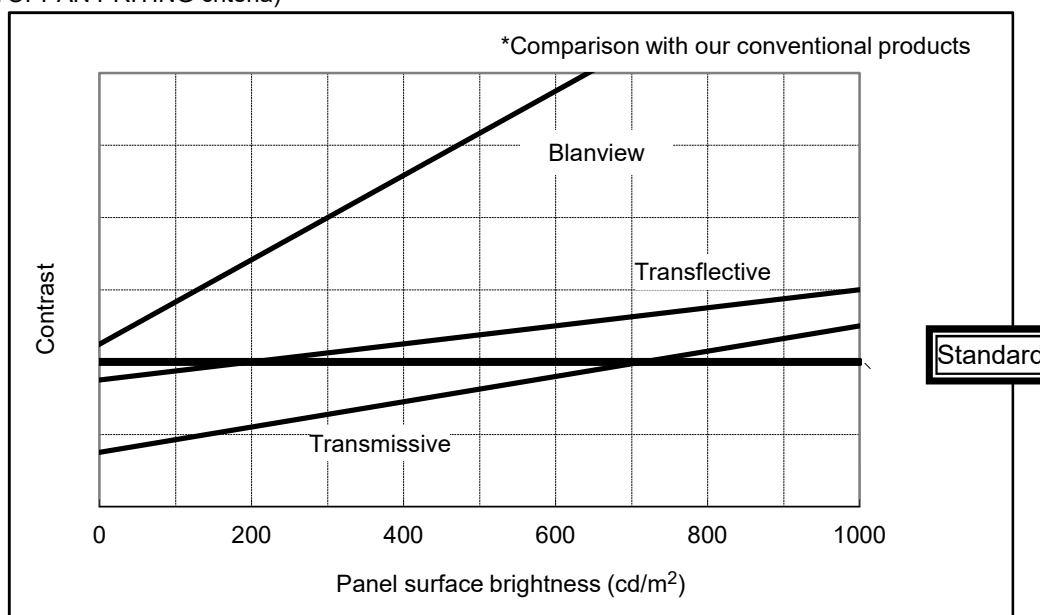

3. Dimensions and Shape

3.1 Dimensions

Items	Specifications	Unit	Remarks
Monitor outline dimensions	42.50[H] × 58.50[V] × 2.55[D]	mm	Exclude FPC cable and parts on FPC.
Active area	36.00[H] × 48.00[V]	mm	60.0mm diagonal
Number of dots	720[H] × 320[V]	dot	
Dot pitch	50.0[H] × 150.0[V]	μ m	
Surface hardness of the polarizer	3	H	Load: 4.90N
Weight	13.5	g	Include FPC cable

3.2 Outward Foam

EC No.	REV. No.	REVISE	DATE (Y:M:D)	APPROVED	CHECKED	PREPARED
--------	----------	--------	--------------	----------	---------	----------

(8/32)
19TLM072
Issue:Feb.5,2020

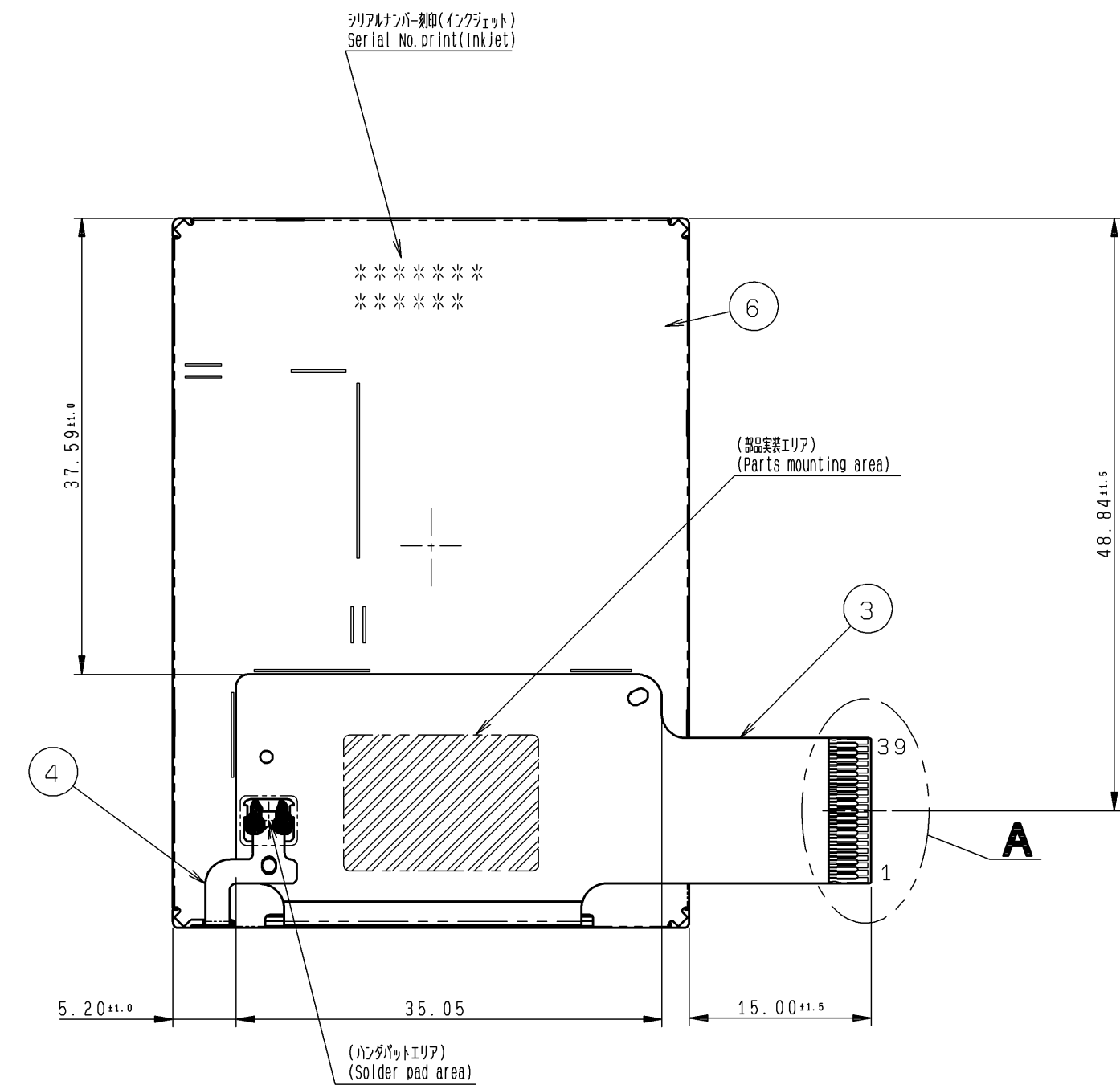
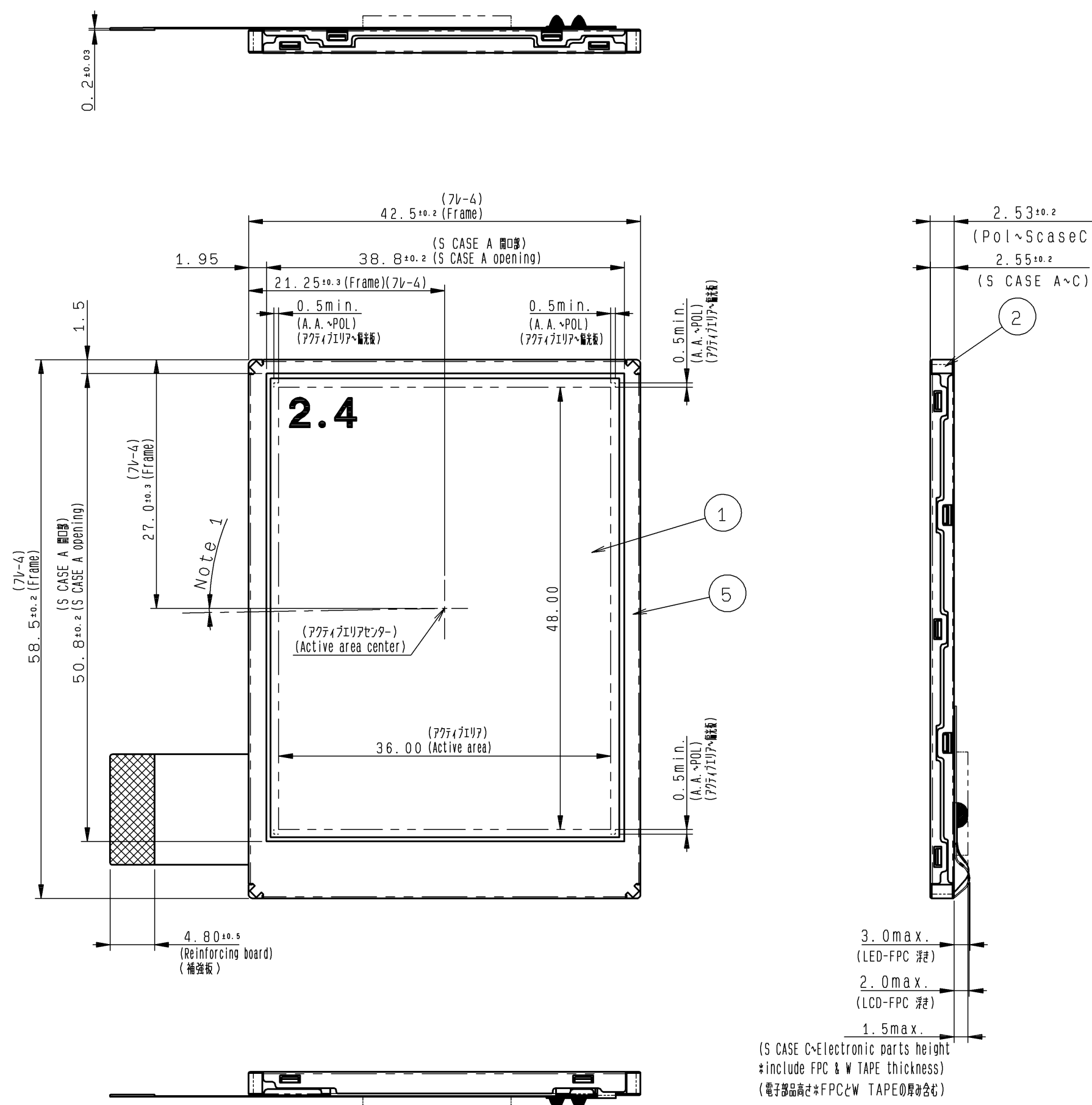

3.0max.
(LED-FPC 高さ)
2.0max.
(LCD-FPC 高さ)
1.5max.
(S CASE C-Electronic parts height
*include FPC & W TAPE thickness)
(電子部品高さ+FPCとW TAPEの厚み合計)

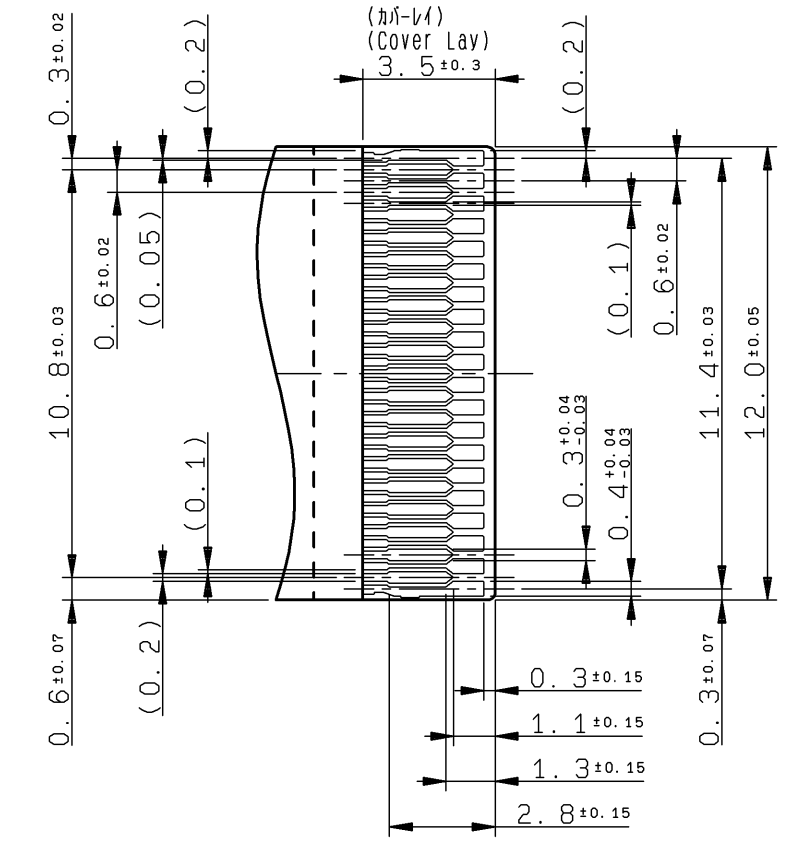
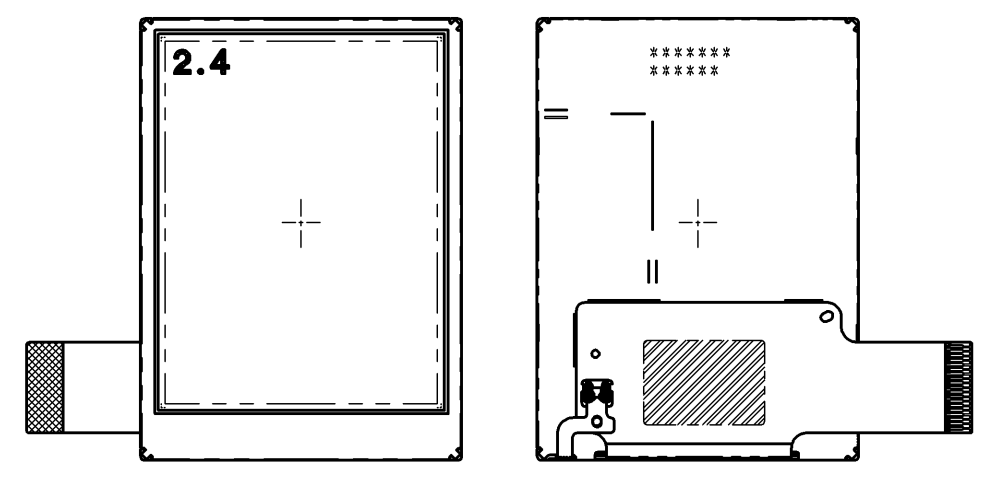

Detail A
(S=5/1)

Angular deviation of LCD cell from the TFT-LCD monitor's reference axis shall be less than ±40'.
1. LCD PANELの角度ス'は、モニター基準軸に対し【±40'】以下とする。
Recommended FPC connectors
For LCD : HIROSE, part number: FH23-39S-0.3SHW(05) (Bottom contact)
2. FPCの接続コネクタの規格(部品)を下記に示す。
ヒロセ電機
部品規格: FH23-39S-0.3SHW(05) (下接点)

	10			
	9			
	8			
	7			
S CASE C	6			
S CASE A	5			
LED-FPC	4			
LCD-FPC	3			
FRAME	2		PC	
LCD	1		Glass substrate thickness=0.5t	with protection sheet
PART NAME	ITEM	PART CODE	MODEL NUMBER	REMARK
APPROVED 尾木	GENERAL TOLERANCE ±0.5	SCALE 2/1	UNIT mm	TOPPAN TOPPAN PRINTING CO., LTD. DO NOT DUPLICATE, CONFIDENTIAL AND PROPRIETARY DRAWING No. REV. SHEET DIV.
CHECKED 加藤真一	ISSUE (Y:M:D) 19:06:19	MODEL CQM24H2P71U**		
CHECKED	NAME			
DESIGN 栗津				
DRAW 栗津				
OUTLINE-D2P71				RJD530470D201

3.3 Serial No. print (S-print)

1) Display Items

S-print indicates the least significant digit of manufacture year (1digit), manufacture month with below alphabet (1letter), model code (5characters), serial number (6digits).

* Contents of Display

*	*	*****	*****
-	-	-	-
a	b	c	d

Contents of display				
a	The least significant digit of manufacture year			
b	Manufacture month	Jan-A Feb-B Mar-C Apr-D	May-E Jun-F Jul-G Aug-H	Sep-I Oct-J Nov-K Dec-L
c	Model code	24BMC (Made in Japan) 24BNC (Made in Malaysia)		
d	Serial number			

* Example of indication of Serial No. print (S-print)

•Made in Japan

9J24BMC500125

means "manufactured in October 2019, 2.4" BM type, C specifications, serial number 500125"

•Made in Malaysia

9J24BNC500125

means "manufactured in October 2019, 2.4" BN type, C specifications, serial number 500125"

2) Location of Serial No. print (S-print)

Refer to 3.2 "Outward form".

3)Others

Please note that it is likely to disappear with an organic solvent about the Serial print.

4. Pin Assignment

No.	Symbol	Functions
1	VSS	Ground
2	VSS	Ground
3	VDD	Power supply
4	VCCIO	Power supply
5	VSS	Ground
6	RESETB	Reset signal. When RESETB is Lo, an internal reset is performed.
7	HSYNC	Horizontal sync signal input. (Low active)
8	VSYNC	Vertical sync signal input. (Low active)
9	CLK	Clock signal for data latching and internal counter of the timing controller
10	VSS	Ground
11	D00	Display data(B) 00h: Black D00:LSB D05:MSB Driver has internal gamma conversion.
12	D01	
13	D02	
14	D03	
15	D04	
16	D05	
17	D10	Display data(G) 00h: Black D10:LSB D15:MSB Driver has internal gamma conversion.
18	D11	
19	D12	
20	D13	
21	D14	
22	D15	
23	D20	Display data(R) 00h: Black D20:LSB D25:MSB Driver has internal gamma conversion.
24	D21	
25	D22	
26	D23	
27	D24	
28	D25	
29	TEST1	Connect to Ground.
30	DE	Input data effective signal. (It is effective for the period of "H")
31	STBYB	Standby signal (Lo:Standby operation,Hi:Normal operation)
32	TEST2	Connect to Ground.
33	NC	OPEN
34	NC	OPEN
35	NC	OPEN
36	NC	OPEN
37	UD/LR	Up Down/Left Right Display reverse(Low or OPEN:normal, High:inversion)
38	BLH	LED drive power source (Anode side)
39	BLL	LED drive power source (Cathode side)

- Recommended connector: HIROSE ELECTRIC FH23 series [FH23-39S-0.3SHW(05)]
- Please make sure to check a consistency between pin assignment in "3.2 Outward Form" and your connector pin assignment when designing your circuit.
Inconsistency in input signal assignment may cause a malfunction.
- Since FPC cable has gold plated terminals, gilt finish contact shoe connector is recommended.

5. Absolute Maximum Rating

VSS=0V

Item	Symbol	Condition	Rating		Unit	Applicable terminal
			MIN	MAX		
Supply voltage	VDD	Ta=25°C	-0.3	4.6	V	VDD
Supply voltage	VCCIO		-0.3	4.6	V	VCCIO
Input voltage for logic	VI		-0.3	VCCIO+0.3	V	Note 1
LED forward current	IL	Ta = 25°C	—	35.0	mA	BLH - BLL
		Ta = 85°C	—	8.5		
Storage temperature range	Tstg		-40	95	°C	
Storage humidity range	Hstg	Non condensing in an environmental moisture at or less than 40°C90%RH				

Note 1: Applicable for RESETB,STBYB,TEST1,TEST2,CLK,HSYNC,VSYSN,DE,D[25:20],D[15:10],D[05:00],UD/LR

6. Recommended Operating Conditions

VSS=0V

Item	Symbol	Condition	Rating			Unit	Applicable terminal
			MIN	TYP	MAX		
Supply voltage	VDD		3.0	3.3	3.6	V	VDD
Supply voltage	VCCIO		1.7	3.3	3.6	V	VCCIO
Input voltage for logic	VI		0	—	VCCIO	V	Note 1
Operational temperature range Note 2	Top	Note 3	-30	25	85	°C	Surface of panel
Operating humidity range	Hop	Ta ≤ 40°C	20	—	85	%	
		Ta > 40°C	Non condensing in an environmental moisture at or less than 40°C85%RH.				

Note 1: Applicable for RESETB,STBYB,TEST1,TEST2,CLK,HSYNC,VSYSN,DE,D[25:20],D[15:10],D[05:00],UD/LR

Note 2: This monitor is operable in this temperature range. With regard to optical characteristics, refer to Item "12. CHARACTERISTICS".

Note 3: Acceptable Forward Current to LED is up to 8.5mA, when Ta=+85°C.
Do not exceed Allowable Forward Current shown on the chart below.

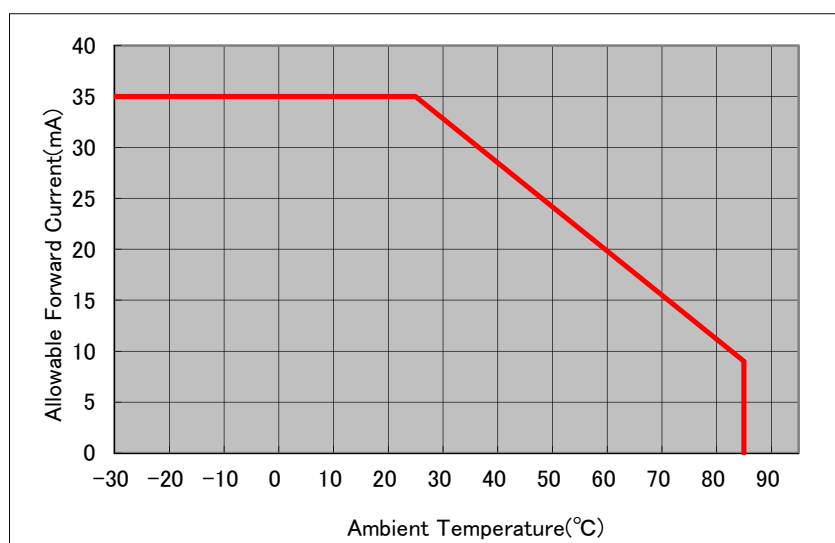

Fig. 2: Allowable Forward Current

7. Electrical Characteristics

7.1 DC Characteristics



7.1.1 Display Module

(Unless otherwise noted, Ta=25°C, VDD=3.3V, VCCIO=3.3V, VSS=0V)

Item	Symbol	Condition	Rating			Unit	Applicable terminals
			MIN	TYP	MAX		
Input Signal Voltage	VIH	VCCIO = 1.7~3.6V	0.8×VCCIO	—	VCCIO	V	Note 1
	VIL		0	—	0.2×VCCIO	V	
Operating Current	IDD	fCLK=6.04MHz Color bar display	—	14.0	28.0	mA	VDD
	ICCIO		—	185	370	μA	VCCIO

Note 1: Applicable for RESETB, STBYB, TEST1, TEST2, CLK, HSYNC, VSYNC, DE, D[25:20], D[15:10], D[05:00], UD/LR

7.1.2 Backlight

Item	Symbol	Condition	Rating			Unit	Applicable terminal
			MIN	TYP	MAX		
Forward current	IL25	Ta=25°C	—	7.5	35.0	mA	BLH - BLL (Reference Value)
	IL85	Ta=85°C	—	—	8.5	mA	
Forward voltage	VL	Ta=25°C, IL=7.5mA	—	5.4	5.7	V	
Estimated Life of LED	LL	Ta=25°C, IL=7.5mA Note2	—	50,000	—	hr	

Note2: - The lifetime of the LED is defined as a period till the brightness of the LED decreases to the half of its initial value.

- This figure is given as a reference purpose only, and not as a guarantee.
- This figure is estimated for an LED operating alone.

As the performance of an LED may differ when assembled as a monitor together with a TFT panel due to different environmental temperature.

- Estimated lifetime could vary on a different temperature and usually higher temperature could reduce the life significantly.

7.2 AC Characteristics

(Unless otherwise noted, Ta=25°C, VDD=3.3V, VCCIO=3.3V, VSS=0V)

Item	Symbol	Condition	Rating			Unit	Applicable terminal
			MIN	TYP	MAX		
CLK pulse High duty	PWH		40%	-	60%	1/fCLK	CLK
CLK pulse Low duty	PWL		40%	-	60%	1/fCLK	
CLK rise time	tr		-	-	20%	1/fCLK	
CLK fall time	tf		-	-	20%	1/fCLK	
Data setup time	tds		5	-	-	ns	CLK,DE D[05:00],D[15:10] D[25:20]
Data hold time	tdh		5	-	-	ns	
DE setup time	tdes		5	-	-	ns	
DE hold time	tdeh		5	-	-	ns	
HSYNC setup time	ths		5	-	-	ns	CLK,VSYNC,HSYNC
HSYNC hold time	thh		5	-	-	ns	
VSYNC setup time	tvhs		5	-	-	ns	
VSYNC hold time	tvhh		5	-	-	ns	

8. Switching Waveform Characteristics

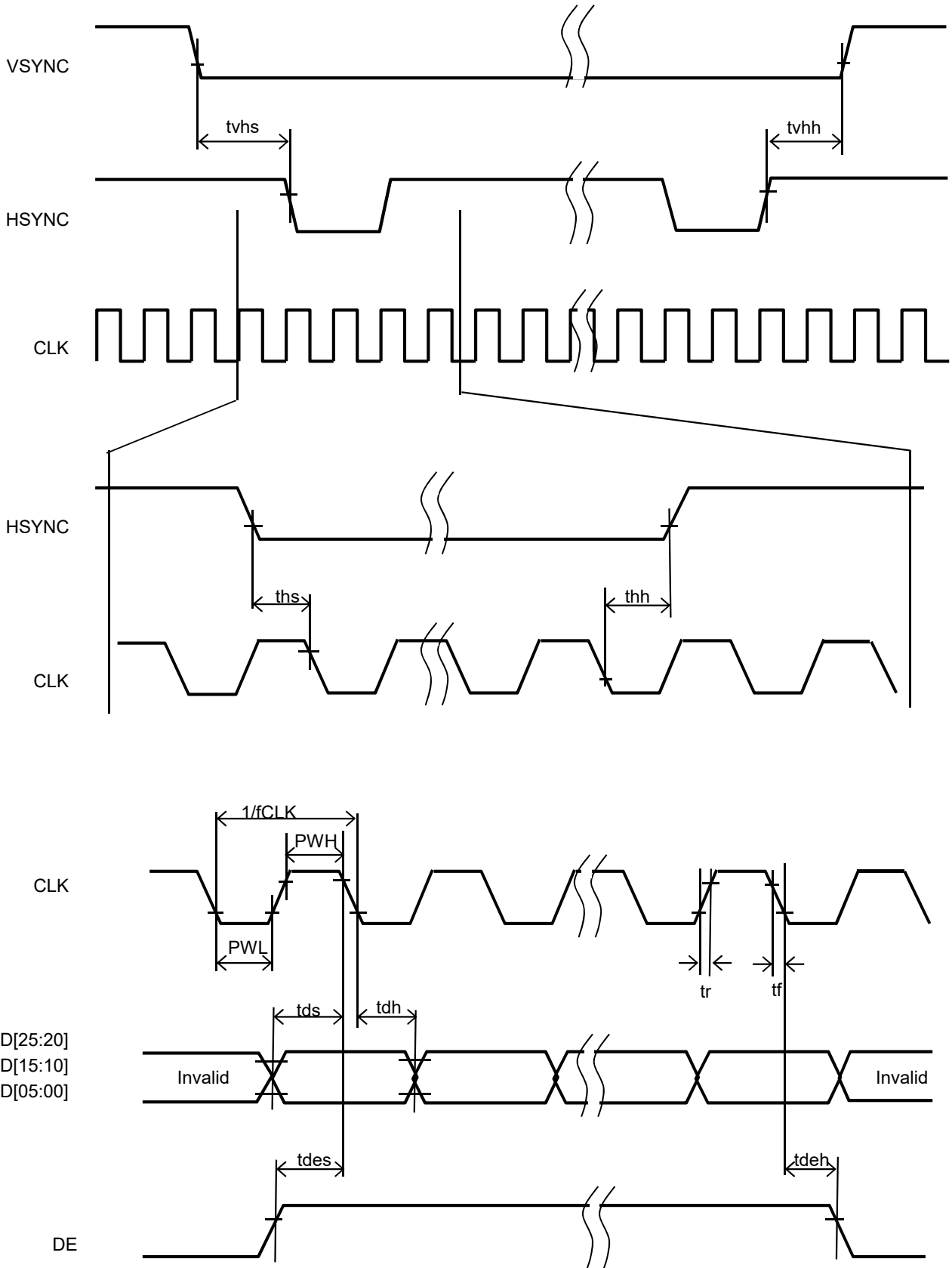

All timings are specified based on the 20% and 80% of VCCIO.

9. Input Timing

9.1 Input Timing Characteristics

(Unless otherwise noted, Ta=25° C, VDD=3.3V, VCCIO=3.3V, VSS=0V)

Item	Symbol	Rating			Unit	Applicable terminal
		MIN	TYP	MAX		
CLK frequency	fCLK	4.77	6.04	8.99	MHz	CLK
VSYNC frequency	fVSYNC	54	60	66	Hz	VSYNC
Vertical period	VP	326	340	370	H	VSYNC
VSYNC pulse width	tVSW	1	2	6	H	VSYNC
Vertical back-porch	tVBP	1	10	31	H	VSYNC, DE
Vertical front-porch	tVFP	5	10	19	H	VSYNC, DE
Vertical valid data	Vdisp	320			H	VSYNC, DE
Horizontal period	HP	271	296	368	CLK	HSYNC
HSYNC pulse width	tHSW	15	20	100	CLK	HSYNC
Horizontal back-porch	tHBP	16	40	100	CLK	HSYNC, DE
Horizontal front-porch	tHFP	15	16	28	CLK	HSYNC, DE
Horizontal DE period	Hde	240			CLK	HSYNC, DE

9.2 Input Timing Chart

< Vertical Timing >

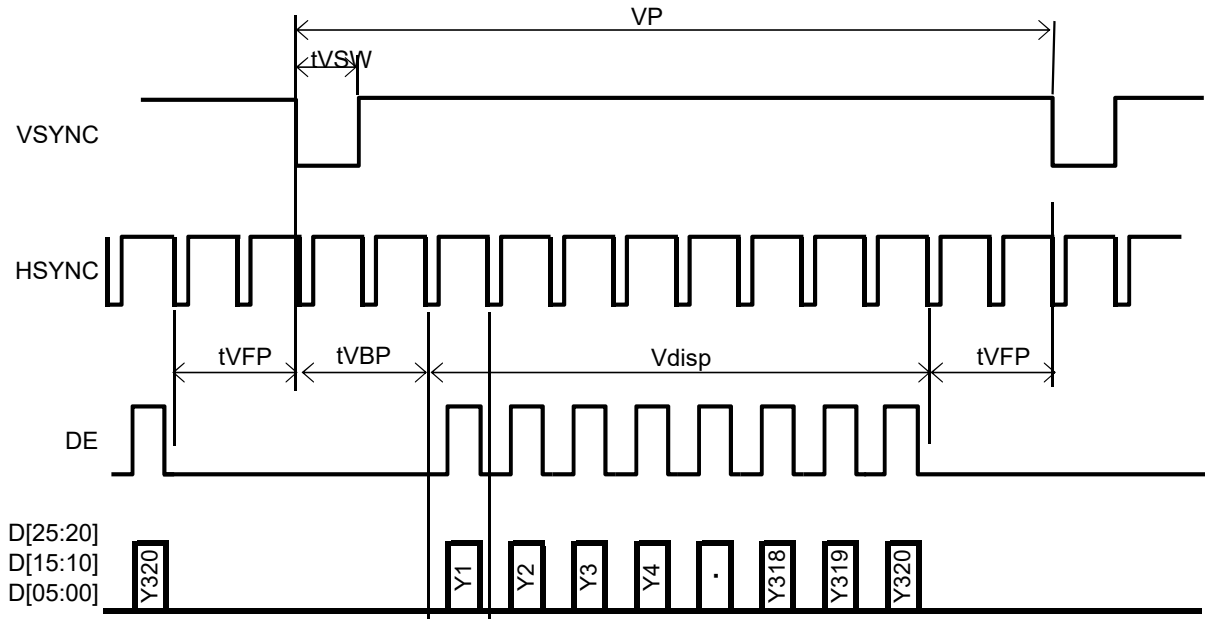

< Horizontal Timing >

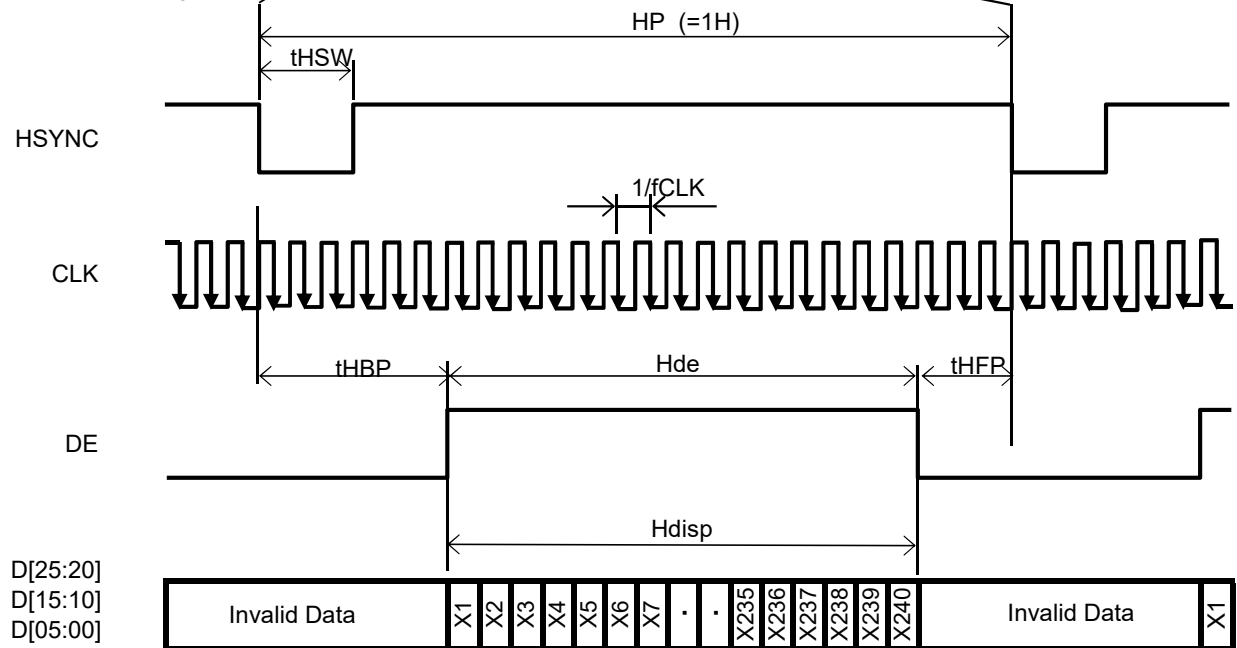

10. Power ON/OFF sequence

Power ON Sequence

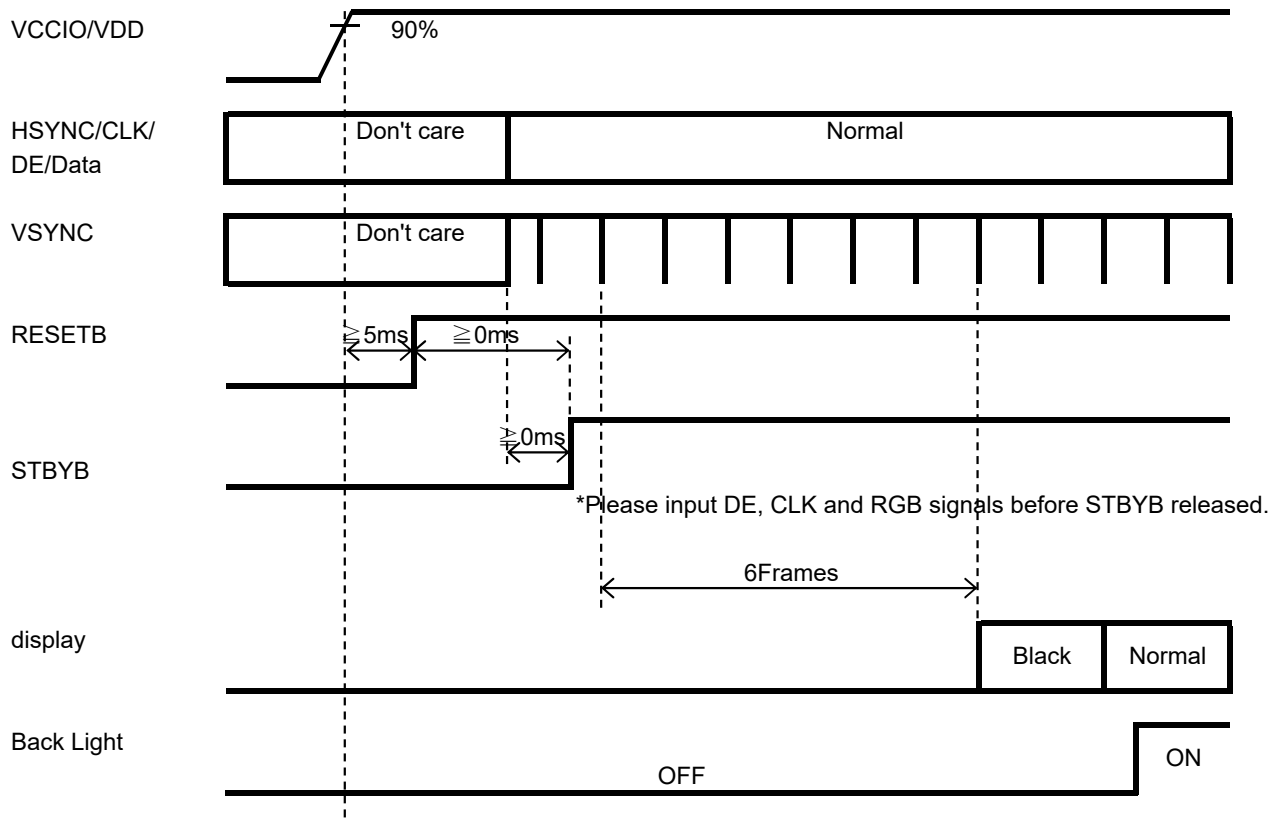

Power OFF Sequence

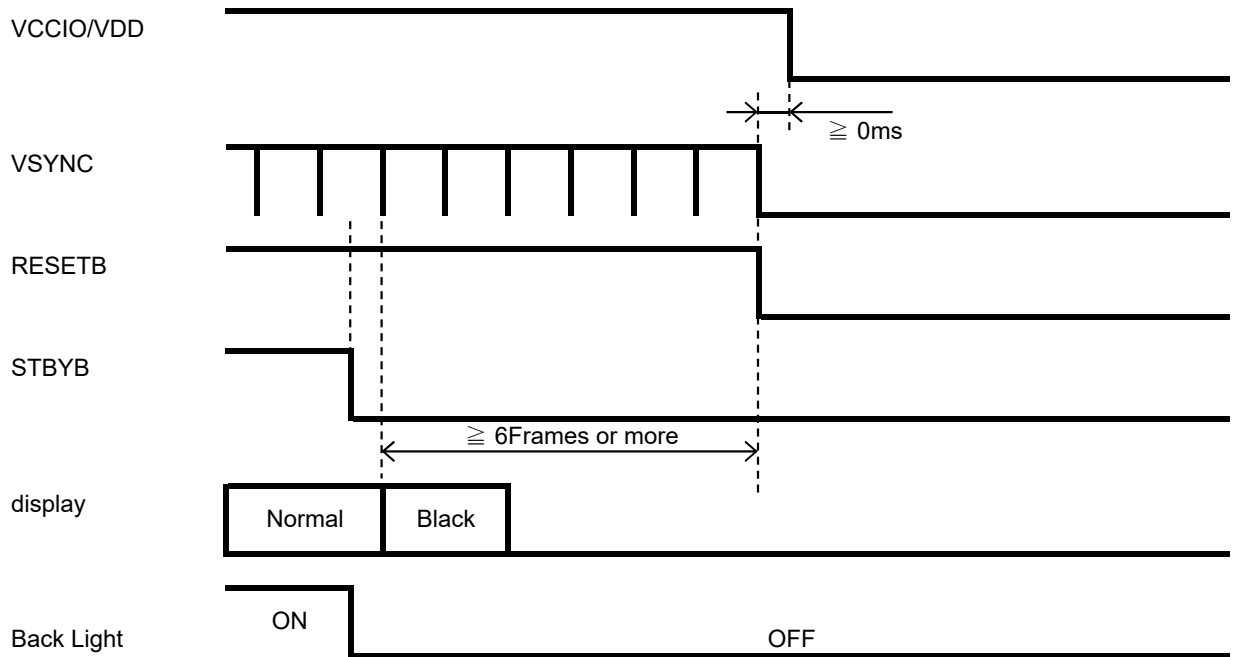

11. LED Circuit

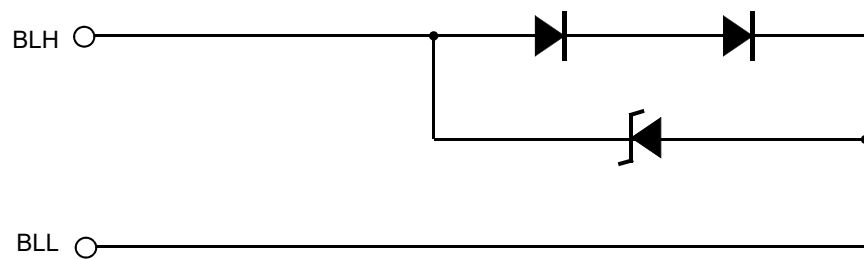

12. Characteristics

12.1 Optical Characteristics

< Measurement Condition >

Measuring instruments: CS2000 (KONICA MINOLTA), LCD7200 (OTSUKA ELECTRONICS),
EZcontrast160D (ELDIM)

Driving condition: VDD = 3.3V, VSS = 0V
Optimized VCOMDC

Backlight: IL=7.5mA

Measured temperature: Ta=25° C

Item		Symbol	Condition	MIN	TYP	MAX	Unit	Note No.	Remark
Response time	Rise time + Fall time	TON	[Data]= 00h→3Fh	—	50	100	ms	1	
		TOFF	[Data]= 3Fh→00h						
Contrast ratio	Backlight ON	CR	[Data]= 3Fh / 00h	400	800	—		2	
	Backlight OFF			—	2	—			
Viewing angle	Left	θL	[Data]= 3Fh / 00h CR ≥ 10	80	—	—	deg	3	
	Right	θR		80	—	—	deg		
	Up	φU		80	—	—	deg		
	Down	φD		80	—	—	deg		
White Chromaticity	x		[Data]=3Fh	White chromaticity range				4	
	y								
Burn-in				No noticeable burn-in image shall be observed after 2 hours of window pattern display.				5	
Center brightness			[Data]=3Fh	180	270	—	cd/m ²	6	IL=7.5mA
Brightness distribution			[Data]=3Fh	70	—	—	%	7	

* Note number 1 to 7: Refer to the APPENDIX of "Reference Method for Measuring Optical Characteristics".

A

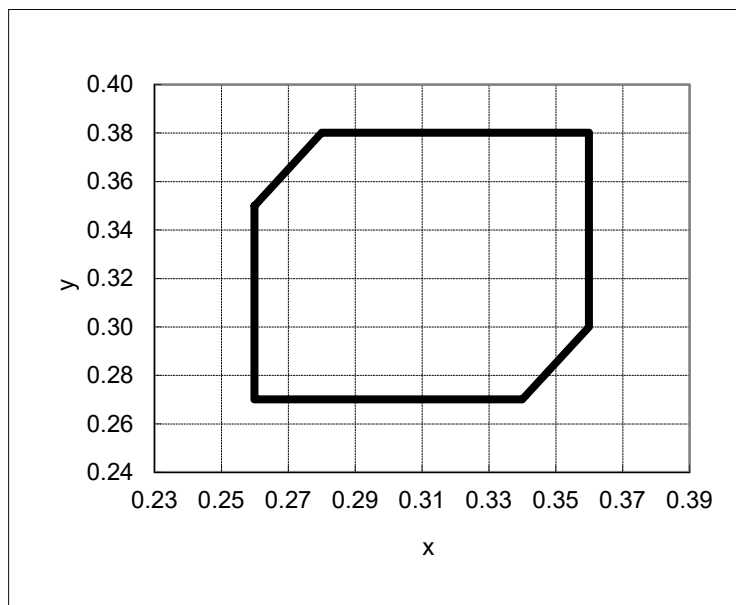

White Chromaticity Range

【White Chromaticity Range】

x	y
0.26	0.35
0.26	0.27
0.34	0.27
0.36	0.30
0.36	0.38
0.28	0.38

12.2 Temperature Characteristics

< Measurement Condition >

Measuring instruments: CS2000 (KONICA MINOLTA), LCD7200 (OTSUKA ELECTRONICS)

Driving condition: VDD = 3.3V, VSS = 0V

Optimized VCOMDC

Backlight: IL=7.5mA

Item	Symbol	Specification			Remark	
		MIN	TYP	MAX		
Contrast ratio	CR	200	—	—	Ta=-30°C Backlight ON	
		200	—	—	Ta=85°C Backlight ON	
Response time	Rise time + Fall time	TON + TOFF	—	1500ms	2200ms	Ta=-30°C
			—	40ms	80ms	Ta=85°C
Display Quality		No noticeable display defect or ununiformity should be observed.				

A

13. Criteria of Judgment

 13.1 Defective Display and Screen Quality

Test Condition:	Observed TFT-LCD monitor from front during operation with the following conditions
Driving Signal	Raster Patter (RGB, white, black)
Signal condition	[Data]:00h,25h,3Fh(3steps)
Observation distance	30 cm
Illuminance	200 to 350 lx
Backlight	IL=7.5mA

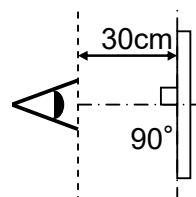

Defect item	Defect content	Criteria		
Display Quality	Line defect	Black, white or color line, 3 or more neighboring defective dots	Not exists	
	Dot defect	Uneven brightness on dot-by-dot base due to defective TFT or CF, or dust is counted as dot defect (brighter dot, darker dot)	Refer to table 1	
		High bright dot: Visible through 2% ND filter at [Data]=00h	Acceptable	
		Low bright dot: Visible through 5% ND filter at [Data]=00h		
Screen Quality	Dirt	Uneven brightness (white stain, black stain etc)	Invisible through 5% ND filter at Black screen. Invisible through 1% ND filter at other screen.	
	Foreign particle	Point-like	$0.25\text{mm} < \phi$	N=0
			$0.20\text{mm} < \phi \leq 0.25\text{mm}$	$N \leq 2$
			$\phi \leq 0.20\text{mm}$	Acceptable
	Liner	$3.0\text{mm} < \text{length and } 0.08\text{mm} < \text{width}$	N=0	
		$\text{length} \leq 3.0\text{mm}$ or $\text{width} \leq 0.08\text{mm}$	Acceptable	
Others		Use boundary sample for judgment when necessary		

 $\phi(\text{mm})$: Average diameter = (major axis + minor axis)/2

Permissible number: N

Table 1

Area	High bright dot	Low bright dot	Dark dot	Total	Criteria
A	0	2	2	3	Permissible distance between same color bright dots (includes neighboring dots): 3 mm or more Permissible distance between same color high bright dots (includes neighboring dots): 5 mm or more
B	2	4	4	5	
Total	2	4	4	5	

13.2 Screen and Other Appearance

Testing conditions

Observation distance 30cm
 Illuminance 1200~2000 lx

Item		Criteria	Remark
Polarizer	Flaw	Ignore invisible defect when the backlight is on.	Applicable area: Active area only (Refer to the section 3.2 "Outward form")
	Stain		
	Bubble		
	Dust		
	Dent		
S-case		No functional defect occurs	
FPC cable		No functional defect occurs	

A 14. Reliability Test

Test item		Test condition		number of failures /number of examinations
Durability test	High temperature storage	Ta=95° C	500hrs	0/3
	Low temperature storage	Ta=-40° C	500hrs	0/3
	High temperature & high humidity storage	Ta=60° C, RH=90% non condensing	500hrs	0/3
	High temperature operation	Tp=85° C	500hrs	0/3
	Low temperature operation	Tp=-30° C	500hrs	0/3
	High temp & humid operation	Tp=40° C, RH=90% non condensing	500hrs	0/3
	Thermal shock storage	-40←→95° C(30min/30min)	100 cycles	0/3
	Lightfastness	Xenon Blackpanel 63±3° C non-shower 450W/m ² (300~700nm) non-operating Integral dose 800MJ/m ²		0/3
Mechanical environmental test	Electrostatic discharge test (Non operation)	Confirms to EIAJ ED-4701/300 C=200pF,R=0Ω,V=±200V Each 3 times of discharge on and power supply and other terminals.		0/3
	Surface discharge test (Non operation)	C=250pF, R=100Ω, V=±12kV Each 5 times of discharge in both polarities on the center of screen with the case grounded.		0/3
	Vibration test	Total amplitude 1.5mm, f=10~55Hz, X,Y,Z directions for each 2 hours		0/3
	Impact test	Use TOPPAN PRINTING original jig (see next page)and make an impact with peak acceleration of 1000m/s ² for 6 msec with half sine-curve at 3 times to each X, Y, Z directions in conformance with JIS 60068-2-27-2011.		0/3
Packing test	Packing vibration-proof test	Acceleration of 19.6m/s ² with frequency of 10→55→10Hz, X,Y, Zdirection for each 30 minutes		0/1 packing
	Packing drop test	Drop from 75cm high. 1 time to each 6 surfaces, 3 edges, 1 corner		0/1 packing

Note:Ta=ambient temperature Tp=Panel temperature

※ The profile of high temperature/humidity storage and High Temperature/humidity operation
(Pure water of over 10MΩ·cm shall be used.)

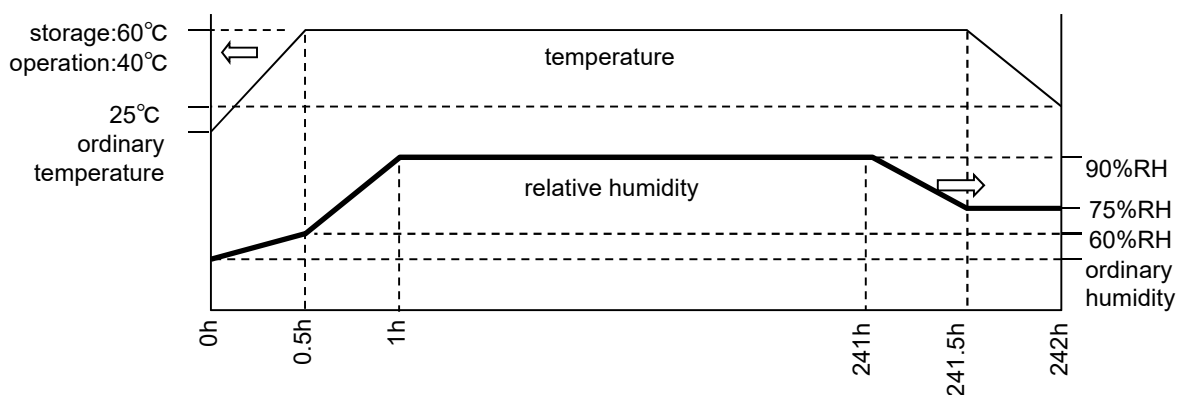

Reliability Criteria

Measure the parameters after leaving the monitor at the ordinary temperature for 24 hours or more after the test completion.

item	Standard	Remark
Display quality	No visible abnormality shall be seen.	As criteria of "13 Criteria of Judgment".
Contrast ratio	200 or more	Backlight ON

TOPPAN PRINTING Original Jig

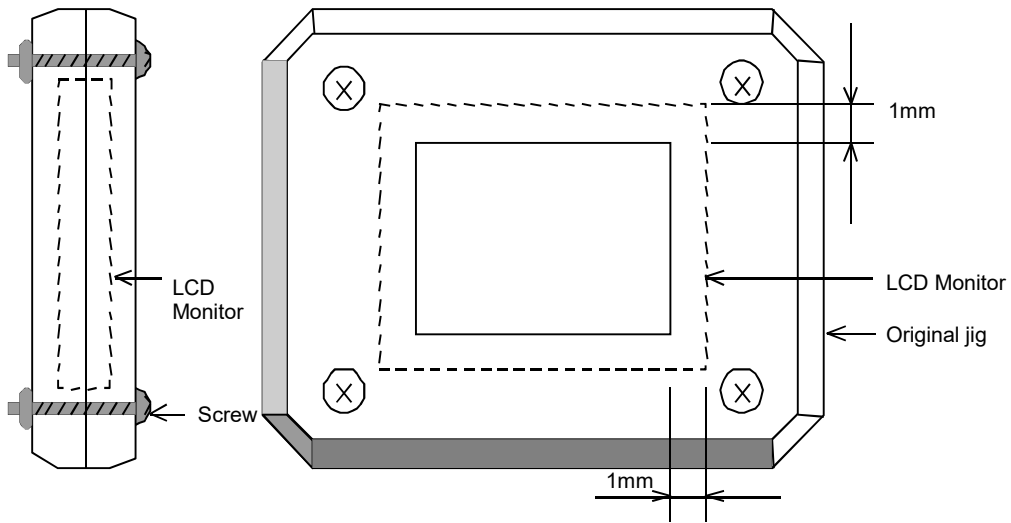

△ 15. Packing Specifications

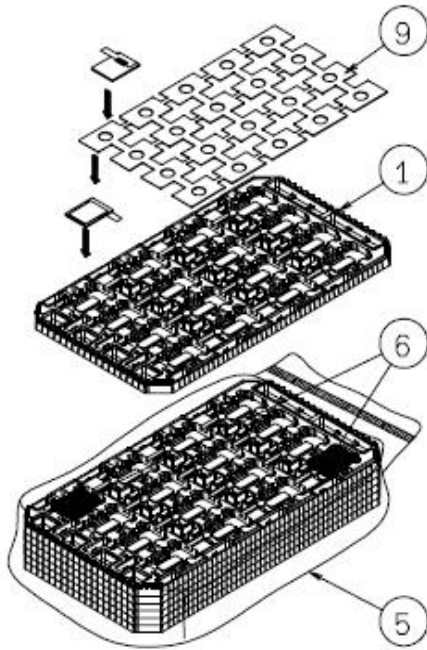

- Step1. • Each lower products are to be placed in one of the cut-outs of the tray with the LCD surface facing upward, and foam-sheet is put on products.
• Upper products are to be placed with the LCD surface facing downward.
- Step2. • Trays be in a stack of 5.
• One empty tray is to be put on the top of stack of 5 packed trays.
- Step3. • 2 packs of moisture absorbers are to be placed on the top tray as shown in the drawing.
• Put piled trays into a sealing bag.
- Step4. • Vacuum and seal the sealing bag with the vacuum sealing machine.
- Step5. • The piled trays are to be wrapped with a bubble cushioning sheet., and to be fixed with adhesive tape.
- Step6. • A corrugated board is to be placed in the bottom of an outer carton.
• The wrapped trays are to be put on the corrugated board in the outer carton.
- Step7. • The outer carton is to be sealed in H-shape with packing tape as shown in the drawing.
• The model number, quantity of products, and shipping date are to be printed on the 2 opposite sides of the outer carton with black ink.
• In necessary, shipping labels or impression markings are to be put on the outer carton.
- Step8. • The outer carton is to be inserted into a extra outer carton with same orientation.
• The extra outer carton is to be sealed H-shape with packing tape as shown in the drawing.
- Step9. • The model number, quantity of products, and shipping date are to be printed on the 2 opposite sides of the extra outer carton with black ink.
• In necessary, shipping labels or impression markings are to be put on the extra outer carton.

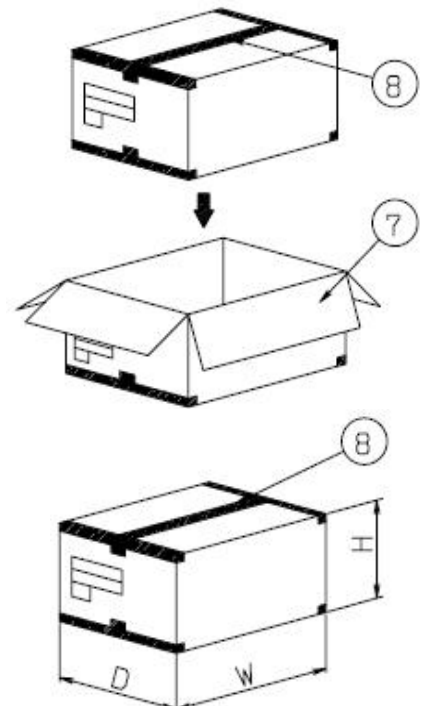
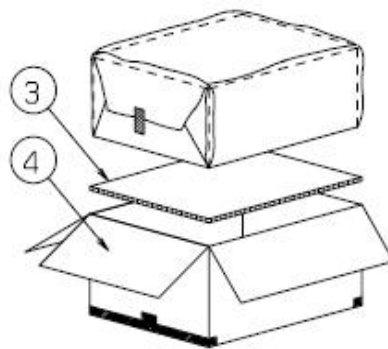
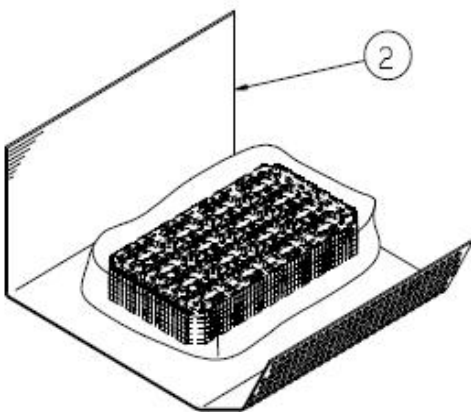

Packing item name		Spec.,Material
①	TRAY	A-PET
②	B SHEET A	Anti-static air babble sheet
③	INNER BOARD	Corrugated cardboard
④	OUTER CARTON	Corrugated cardboard
⑤	SEALING BAG	
⑥	Drier	Moisture absorber
⑦	EXTRA OUTER CARTON	Corrugated cardboard
⑧	Packing tape	
⑧	FOAM SHEET	Anti-static polyethylene

Dimension of extra outer carton	
D : Approx.	(337mm)
W: Approx.	(618mm)
H: Approx.	(179mm)
Quantity of products packed in one carton:	200
Gross weight : Approx.	5.5Kg

16. Handling Instruction

16.1 Cautions for Handling LCD panels

**Caution**

- (1) Do not make an impact on the LCD panel glass because it may break and you may get injured from it.
- (2) If the glass breaks, do not touch it with bare hands.
(Fragment of broken glass may stick you or you cut yourself on it.)
- (3) If you get injured, receive adequate first aid and consult a medial doctor.
- (4) Do not let liquid crystal get into your mouth.
(If the LCD panel glass breaks, try not let liquid crystal get into your mouth even toxic property of liquid crystal has not been confirmed.)
- (5) If liquid crystal adheres, rinse it out thoroughly.
(If liquid crystal adheres to your cloth or skin, wipe it off with rubbing alcohol or wash it thoroughly with soap. If liquid crystal gets into eyes, rinse it with clean water for at least 15 minutes and consult an eye doctor.)
- (6) If you scrap this products, follow a disposal standard of industrial waste that is legally valid in the community, country or territory where you reside.
- (7) Do not connect or disconnect this product while its application products is powered on.
- (8) Do not attempt to disassemble or modify this product as it is precision component.
- (9) If a part of soldering part has been exposed, and avoid contact (short-circuit) with a metallic part of the case etc. about FPC of this model, please.
Please insulate it with the insulating tape etc. if necessary.
The defective operation is caused, and there is a possibility to generation of heat and the ignition.
- (10) Since excess current protection circuit is not built in this TFT module, there is the possibility that LCD module or peripheral circuit become feverish and burned in case abnormam operation is generated.
We recommend you to add excess current protection circuit to power supply.
- (11) The devices on the FPC are damageable to electrostatic discharge, because the terminals of the devices are exposed.
Wear grounded wrist-straps and use electrostatic neutralization blowers to prevent static charge and discharge when handling the TFT monitors.
Designate an appropriate operating area, and set equipment, tools, and machines properly when handling this product.

**Caution**

This mark is used to indicate a precaution or an instruction which, if not correctly observed, may result in bodily injury, or material damages alone.

16.2 Precautions for Handling

- 1) Wear finger tips at incoming inspection and for handling the TFT monitors to keep display quality and keep the working area clean.
Do not touch the surface of the monitor as it is easily scratched.
- 2) Wear grounded wrist-straps and use electrostatic neutralization blowers to prevent static charge and discharge when handling the TFT monitors as the LED in this TFT monitors is damageable to electrostatic discharge.
Designate an appropriate operating area, and set equipment, tools, and machines properly when handling this product.
- 3) Avoid strong mechanical shock including knocking, hitting or dropping to the TFT monitors for protecting their glass parts. Do not use the TFT monitors that have been experienced dropping or strong mechanical shock.
- 4) Do not use or storage the TFT monitors at high temperature and high humidity environment. Particularly, never use or storage the TFT monitors at a location where condensation builds up.
- 5) Avoid using and storing TFT monitors at a location where they are exposed to direct sunlight or ultraviolet rays to prevent the LCD panels from deterioration by ultraviolet rays.
- 6) Do not stain or damage the contacts of the FPC cable .
FPC cable needs to be inserted until it can reach to the end of connector slot.
During insertion, make sure to keep the cable in a horizontal position to avoid an oblique insertion.
Otherwise, it may cause poor contact or deteriorate reliability of the FPC cable.
- 7) The FPC cable is a design very weak to the bend and the pull as it is fixed with the tape.
Do not bend or pull the FPC cable or carry the TFT monitor by holding the FPC cable.
- 8) Peel off the protective film on the TFT monitors during mounting process.
Refer to the section 16.5 on how to peel off the protective film.
We are not responsible for electrostatic discharge failures or other defects occur when peeling off the protective film.
-  9) Please make it to the structure to suppress surroundings of the front polarizer for the display irregularity prevention.

16.3 Precautions for Operation

- 1) Since this TFT monitors are not equipped with light shielding for the driver IC, do not expose the driver IC to strong lights during operation as it may cause functional failures.
- 2) In case of powering up or powering off this LCD module, be sure to comply the sequence as instructed in this specification.
- 3) Do not plug in or out the FPC cable while power supply is switch on.
Plug the FPC cable in and out while power supply is switched off.
- 4) Do not operate the TFT monitors in the strong magnetic field. It may break the TFT monitors.
- 5) Do not display a fixed image on the screen for a long time.
Use a screen-saver or other measures to avoid a fixed image displayed on the screen for a long time. Otherwise, it may cause burn-in image on the screen due the characteristics of liquid crystal.



16.4 Storage Condition for Shipping Cartons

Storage environment

- Temperature 0 to 40° C
- Humidity 60%RH or less
No-condensing occurs under low temperature with high humidity condition.
- Atmosphere No poisonous gas that can erode electronic components and/or wiring materials should be detected.
- Time period 1 year
- Unpacking To prevent damages caused by static electricity, anti-static precautionary measures (e.g. earthing, anti-static mat) should be implemented.
- Maximum piling up 7 cartons

*Conditions to storage after unpacking

Storage environment

- Temperature 0 to 40° C
- Humidity 60%RH or less
No-condensing occurs under low temperature with high humidity condition.
- Atmosphere No poisonous gas that can erode electronic components and/or wiring materials should be detected.
- Time period 1 year (Shelf life)
- Others Keep/ store away from direct sunlight
Storage goods on original tray made by ORTUS.

16.5 Precautions for Peeling off the Protective film

The followings work environment and work method are recommended to prevent the TFT monitors from static damage or adhesion of dust when peeling off the protective films.

A) Work Environment

- a) Humidity: 50 to 70 %RH, Temperature 15 to 27 °C
- b) Operators should wear conductive shoes, conductive clothes, conductive finger tips and grounded wrist-straps. Anti-static treatment should be implemented to work area's floor.
- c) Use a room shielded against outside dust with sticky floor mat laid at the entrance to eliminate dirt.

B) Work Method

The following procedures should taken to prevent the driver ICs from charging and discharging.

- a) Use an electrostatic neutralization blower to blow air on the TFT monitors to its lower right when the LCD-FPC cable is facing to the leftside.
Optimize direction of the blowing air and the distance between the TFT monitors and the electrostatic neutralization blower.
- b) Put an adhesive tape (Scotch tape, etc) at the lower right corner area of the protective film to prevent scratch on surface of TFT monitors.
- c) Peel off the adhesive tape slowly (spending more than 2 secs to complete) by pulling it to opposite direction.

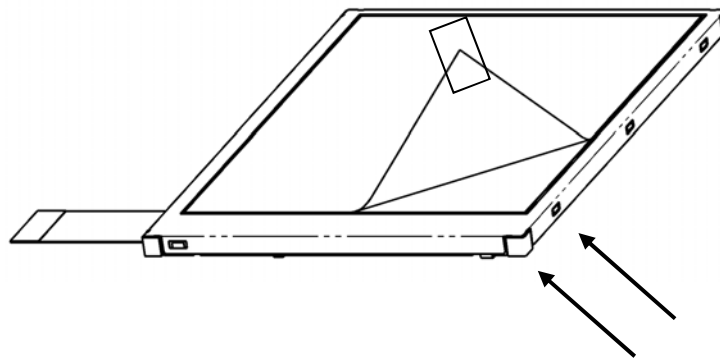

Direction of blowing air
(Optimize air direction and the distance)

16.6 Warranty

TOPPAN PRINTING is only liable to defective goods which is stored and used under the condition complying with this specifications and returned within 1 (one) year.

Warranty caused by manufacturing defect shall be conducted by replacement of goods or refundment at unit price.

APPENDIX

Reference Method for Measuring Optical Characteristics and Performance

1. Measurement Condition (Backlight ON)

Measuring instruments: CS2000 (KONICA MINOLTA), LCD7200 (OTSUKA ELECTRONICS), EZcontrast160D (ELDIM)

Driving condition: Refer to the section "Optical Characteristics"

Measured temperature: 25°C unless specified

Measurement system: See the chart below. The luminance meter is placed on the normal line of measurement system.

Measurement point: At the center of the screen unless otherwise specified

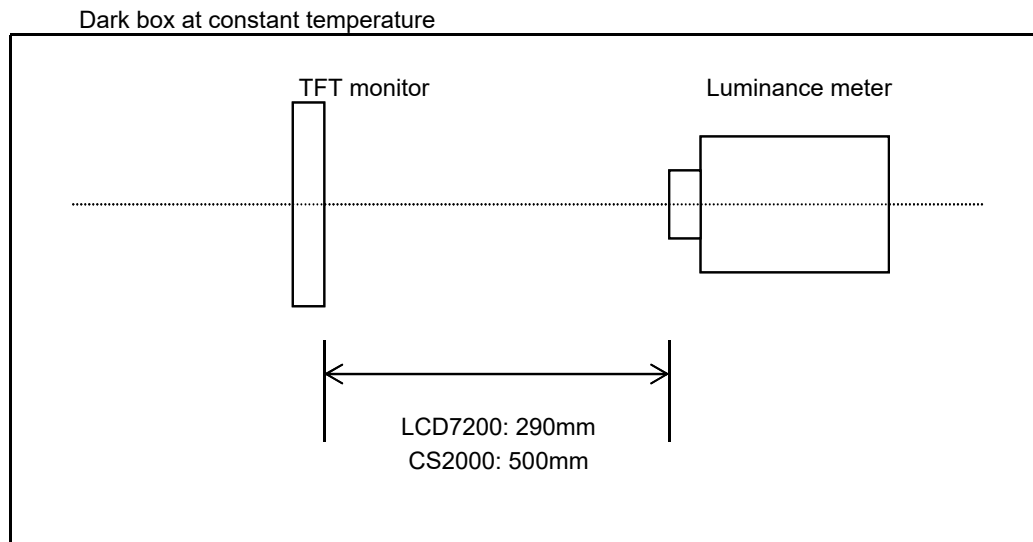

Measurement is made after 30 minutes of lighting of the backlight.

Measurement point: At the center point of the screen
Brightness distribution: 9 points shown in the following drawing.

<Portrait model>

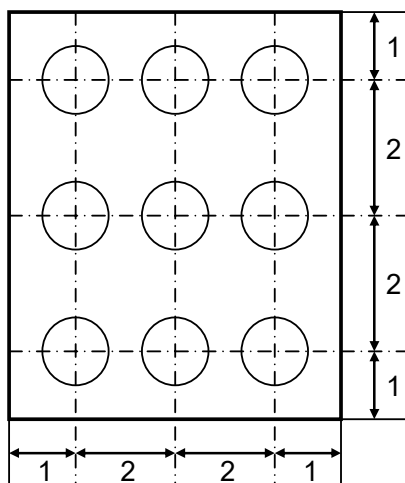

Dimensional ratio of active area

Backlight IL=7.5mA

Measurement Condition (Contrast ratio Backlight OFF only)

- Measuring instruments: LCD7200(OTSUKA ELECTRONICS),Ring Light(40,000 lx, ϕ 58)
- Driving condition: Refer to the section "Optical Characteristics"
- Measured temperature: 25° C unless specified
- Measurement system: See the chart below.
- Measurement point: At the center of the screen.

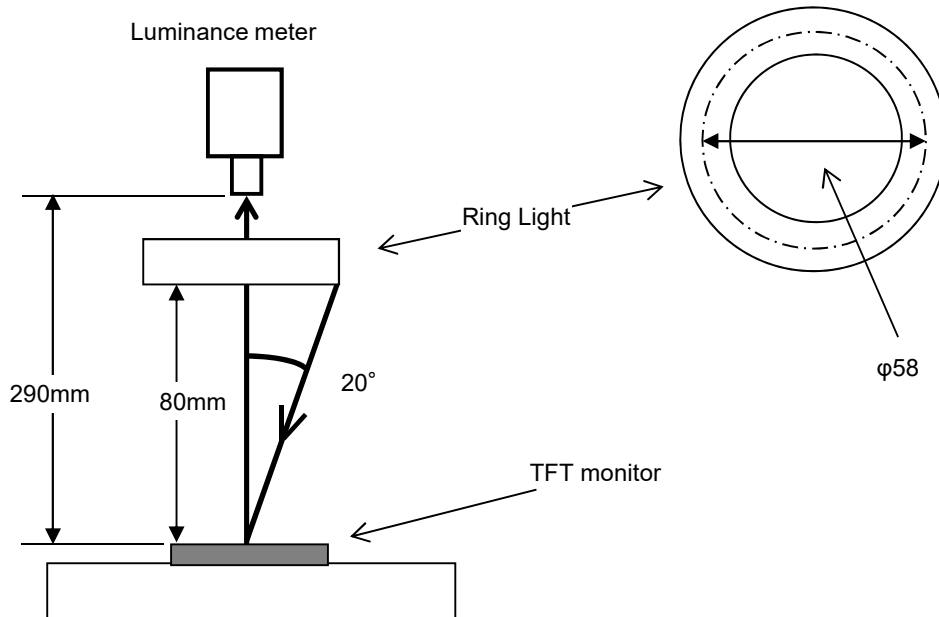

2. Test Method

Notice	Item	Test method	Measuring instrument	Remark
1	Response time	<p>Measure output signal waveform by the luminance meter when raster of window pattern is changed from white to black and from black to white.</p>	LCD7200	<p>Black display [Data]=00h White display [Data]=3Fh TON Rise time TOFF Fall time</p>
2	Contrast ratio	<p>Measure maximum luminance Y1([Data]=3Fh) and minimum luminance Y2([Data]=00h) at the center of the screen by displaying raster or window pattern. Then calculate the ratio between these two values.</p> <p>Contrast ratio = Y1/Y2</p> <p>Diameter of measuring point: 7.8mmφ(CS2000)</p> <p>Diameter of measuring point: 3mmφ(LCD7200)</p>	CS2000 LCD7200	Backlight ON Backlight OFF
3	Viewing angle Horizontalθ Verticalφ	Move the luminance meter from right to left and up and down and determine the angles where contrast ratio is 10.	EZcontrast160D	
4	White chromaticity	<p>Measure chromaticity coordinates x and y of CIE1931 colorimetric system at [Data] = 3Fh</p> <p>Color matching faction: 2°view</p> <p>Measurement angle: 1°</p>	CS2000	
5	Burn-in	Visually check burn-in image on the screen after 2 hours of "window display" ([Data]=3Fh/00h).		At optimized VCOMDC
6	Center brightness	Measure the brightness at the center of the screen.	CS2000	
7	Brightness distribution	<p>(Brightness distribution) = 100 x B/A %</p> <p>A : max. brightness of the 9 points</p> <p>B : min. brightness of the 9 points</p>	CS2000	

Our company network supports you worldwide with offices in Germany, Austria, Switzerland, the UK and the USA. For more information please contact:

Headquarters

Germany



FORTEC Elektronik AG

Augsburger Str. 2b
82110 Germering

Phone: +49 89 894450-0
E-Mail: info@fortecag.de
Internet: www.fortecag.de

Fortec Group Members

Austria



Distec GmbH Office Vienna

Nuschinggasse 12
1230 Wien

Phone: +43 1 8673492-0
E-Mail: info@distec.de
Internet: www.distec.de

Germany



Distec GmbH

Augsburger Str. 2b
82110 Germering

Phone: +49 89 894363-0
E-Mail: info@distec.de
Internet: www.distec.de

Switzerland



ALTRAC AG

Bahnhofstraße 3
5436 Würenlos

Phone: +41 44 7446111
E-Mail: info@altrac.ch
Internet: www.altrac.ch

United Kingdom



Display Technology Ltd.

Osprey House, 1 Osprey Court
Hichingbrooke Business Park
Huntingdon, Cambridgeshire, PE29 6FN

Phone: +44 1480 411600
E-Mail: info@displaytechnology.co.uk
Internet: www.displaytechnology.co.uk

USA



Apollo Display Technologies, Corp.

87 Raynor Avenue,
Unit 1 Ronkonkoma,
NY 11779

Phone: +1 631 5804360
E-Mail: info@apolloDisplays.com
Internet: www.apolloDisplays.com