



OUR GLOBAL  
COMPETENCE  
CENTRES

 APOLLO DISPLAY  
TECHNOLOGIES



 DISTEC



 DISPLAY  
TECHNOLOGY



# Datasheet

## Tianma

**NL10276AC30-42C**

**15.0" TFT Display**

NL-€F-0FJ



# TFT COLOR LCD MODULE

**NL10276AC30-42C**

**38cm (15.0 Type)**

**XGA**

**LVDS interface (1port)**

**DATA SHEET** 

**DOD-PP-2391 (5th edition)**

**This DATA SHEET is updated document from  
DOD-PP-2041(4).**

**All information is subject to change without notice.  
Please confirm the sales representative before  
starting to design your system.**

## INTRODUCTION

The Copyright to this document belongs to Tianma Japan, Ltd. (hereinafter called "TMJ"). No part of this document will be used, reproduced or copied without prior written consent of TMJ.

TMJ does and will not assume any liability for infringement of patents, copyrights or other intellectual property rights of any third party arising out of or in connection with application of the products described herein except for that directly attributable to mechanisms and workmanship thereof. No license, express or implied, is granted under any patent, copyright or other intellectual property right of TMJ.

Some electronic products would fail or malfunction at a certain rate. In spite of every effort to enhance reliability of products by TMJ, the possibility of failures and malfunction might not be avoided entirely. To prevent the risks of damage to death, human bodily injury or other property arising out thereof or in connection therewith, each customer is required to take sufficient measures in its safety designs and plans including, but not limited to, redundant system, fire-containment and anti-failure.

The products are classified into three grades: "**Standard**", "**Special**", and "**Specific**".

Each quality grade is designed for applications described below. Any customer who intends to use a product for application other than that of Standard is required to contact an TMJ sales representative in advance.

The **Standard**: Applications as any failure, malfunction or error of the products are free from any damage to death, human bodily injury or other property (Products Safety Issue) and not related the safety of the public (Social Issues), like general electric devices.

Examples: Office equipment, audio and visual equipment, communication equipment, test and measurement equipment, personal electronic equipment, home electronic appliances, car navigation system (with no vehicle control functions), seat entertainment monitor for vehicles and airplanes, fish finder (except marine radar integrated type), PDA, etc.

The **Special**: Applications as any failure, malfunction or error of the products might directly cause any damage to death, human bodily injury or other property (Products Safety Issue) and the safety of the public (Social Issues) and required high level reliability by conventional wisdom.

Examples: Vehicle/train/ship control system, traffic signals system, traffic information control system, air traffic control system, surgery/operation equipment monitor, disaster/crime prevention system, etc.

The **Specific**: Applications as any failure, malfunction or error of the products might severe cause any damage to death, human bodily injury or other property (Products Safety Issue) and the safety of the public (Social Issues) and developed, designed and manufactured in accordance with the standards or quality assurance program designated by the customer who requires extremely high level reliability and quality.

Examples: Aerospace system (except seat entertainment monitor), nuclear control system, life support system, etc.

The quality grade of this product is the "**Standard**" unless otherwise specified in this document.

## CONTENTS

INTRODUCTION .....	2
<b>1. OUTLINE.....</b>	<b>4</b>
1.1 STRUCTURE AND PRINCIPLE .....	4
1.2 APPLICATION .....	4
1.3 FEATURES .....	4
<b>2. GENERAL SPECIFICATIONS.....</b>	<b>5</b>
<b>3. BLOCK DIAGRAM.....</b>	<b>6</b>
<b>4. DETAILED SPECIFICATIONS.....</b>	<b>7</b>
4.1 MECHANICAL SPECIFICATIONS .....	7
4.2 ABSOLUTE MAXIMUM RATINGS.....	7
4.3 ELECTRICAL CHARACTERISTICS.....	8
4.3.1 LCD panel signal processing board.....	8
4.3.2 LED driver .....	8
4.3.3 Power supply voltage ripple.....	9
4.3.4 Fuse.....	9
4.4 POWER SUPPLY VOLTAGE SEQUENCE.....	10
4.4.1 LCD panel signal processing board.....	10
4.4.2 LED driver .....	10
4.5 CONNECTIONS AND FUNCTIONS FOR INTERFACE PINS .....	11
4.5.1 LCD panel signal processing board.....	11
4.5.2 LED driver .....	12
4.5.3 Positions of socket.....	12
4.5.4 Connection between receiver and transmitter for LVDS.....	13
4.5.5 Input data mapping .....	16
4.6 DISPLAY COLORS AND INPUT DATA SIGNALS.....	17
4.6.1 Combinations of input data signals, FRC and MSL signal.....	17
4.6.2 16,777,216 colors.....	18
4.6.3 262,144 colors.....	19
4.7 DISPLAY POSITIONS .....	20
4.8 INPUT SIGNAL TIMINGS .....	21
4.8.1 Outline of input signal timings .....	21
4.8.2 Timing characteristics.....	22
4.8.3 Input signal timing chart.....	23
4.9 OPTICS.....	24
4.9.1 Optical characteristics.....	24
4.9.2 Definition of contrast ratio.....	25
4.9.3 Definition of luminance uniformity.....	25
4.9.4 Definition of response times .....	25
4.9.5 Definition of viewing angles.....	25
<b>5. ESTIMATED LUMINANCE LIFETIME.....</b>	<b>26</b>
<b>6. RELIABILITY TESTS .....</b>	<b>27</b>
<b>7. PRECAUTIONS .....</b>	<b>28</b>
7.1 MEANING OF CAUTION SIGNS .....	28
7.2 CAUTIONS .....	28
7.3 ATTENTIONS.....	28
7.3.1 Handling of the product .....	28
7.3.2 Environment.....	29
7.3.3 Characteristics.....	29
7.3.4 Others.....	29
<b>8. OUTLINE DRAWINGS.....</b>	<b>30</b>
8.1 FRONT VIEW .....	30
8.2 REAR VIEW .....	31

## 1. OUTLINE

### 1.1 STRUCTURE AND PRINCIPLE

Color LCD module NL10276AC30-42C is composed of the amorphous silicon thin film transistor liquid crystal display (a-Si TFT LCD) panel structure with driver LSIs for driving the TFT (Thin Film Transistor) array and a backlight.

The a-Si TFT LCD panel structure is injected liquid crystal material into a narrow gap between the TFT array glass substrate and a color-filter glass substrate.

Color (Red, Green, Blue) data signals from a host system (e.g. signal generator, etc.) are modulated into best form for active matrix system by a signal processing board, and sent to the driver LSIs which drive the individual TFT arrays.

The TFT array as an electro-optical switch regulates the amount of transmitted light from the backlight assembly, when it is controlled by data signals. Color images are created by regulating the amount of transmitted light through the TFT array of red, green and blue dots.

### 1.2 APPLICATION

- For industrial use

### 1.3 FEATURES

- Adoption of T-EVT (Transmissive-Enhanced View TFT)
- High luminance
- High contrast
- Low reflection
- Wide viewing angle
- Fast response time
- LVDS interface
- Selectable LVDS input map
- Selectable 8-bit or 6-bit digital signals for data of RGB
- Small foot print
- Long life LED backlight built in LED driver
- Replaceable lamp for backlight
- Acquisition product for UL60950-1/CSA C22.2 No.60950-1-03 (File number: E170632)
- Compliant with the European RoHS directive (2011/65/EU)

**2. GENERAL SPECIFICATIONS**

<b>Display area</b>	304.128 (H) × 228.096 (V) mm
<b>Diagonal size of display</b>	38cm (15.0 inches)
<b>Drive system</b>	a-Si TFT active matrix
<b>Display color</b>	16,777,216 colors (At 8-bit input, FRC terminal= Low) 262,144 colors (At 6-bit input, FRC terminal= High or Open)
<b>Pixel</b>	1,024 (H) × 768 (V) pixels
<b>Pixel arrangement</b>	RGB (Red dot, Green dot, Blue dot) vertical stripe
<b>Dot pitch</b>	0.099 (H) × 0.297 (V) mm
<b>Pixel pitch</b>	0.297 (H) × 0.297 (V) mm
<b>Module size</b>	326.5 (W) × 253.5 (H) × 11.8 (D) mm (typ.)
<b>Weight</b>	1,050g (typ.)
<b>Contrast ratio</b>	600:1 (typ.)
<b>Viewing angle</b>	At the contrast ratio $\geq 10:1$ <ul style="list-style-type: none"> <li>• Horizontal: Right side 80° (typ.), Left side 80° (typ.)</li> <li>• Vertical: Up side 80° (typ.), Down side 80° (typ.)</li> </ul>
<b>Designed viewing direction</b>	<ul style="list-style-type: none"> <li>• Viewing direction without image reversal: Up side (12 o'clock)</li> <li>• Viewing direction with contrast peak: Down side (6 o'clock)</li> <li>• Viewing angle with optimum grayscale (<math>\gamma=2.2</math>): Normal axis (perpendicular)</li> </ul>
<b>Polarizer surface</b>	Clear + Antireflection (AR)
<b>Polarizer pencil-hardness</b>	2H (min.) [by JIS K5600]
<b>Color gamut</b>	At LCD panel center 60% (typ.) [against NTSC color space]
<b>Response time</b>	$T_{on}+T_{off}$ (10% $\leftrightarrow$ 90%) 8ms (typ.)
<b>Luminance</b>	At the maximum luminance control 600cd/m <sup>2</sup> (typ.)
<b>Signal system</b>	LVDS interface (1port)
<b>Power supply voltage</b>	LCD panel signal processing board: 3.3V LED driver: 12.0V
<b>Backlight</b>	LED backlight <div style="border-left: 1px solid black; border-right: 1px solid black; padding: 5px; margin-left: 20px;">           Replaceable part  <ul style="list-style-type: none"> <li>• Lamp holder set: 150LHS202</li> </ul> </div>
<b>Power consumption</b>	At the maximum luminance control, Checkered flag pattern 11.9W (typ.)

**3. BLOCK DIAGRAM**

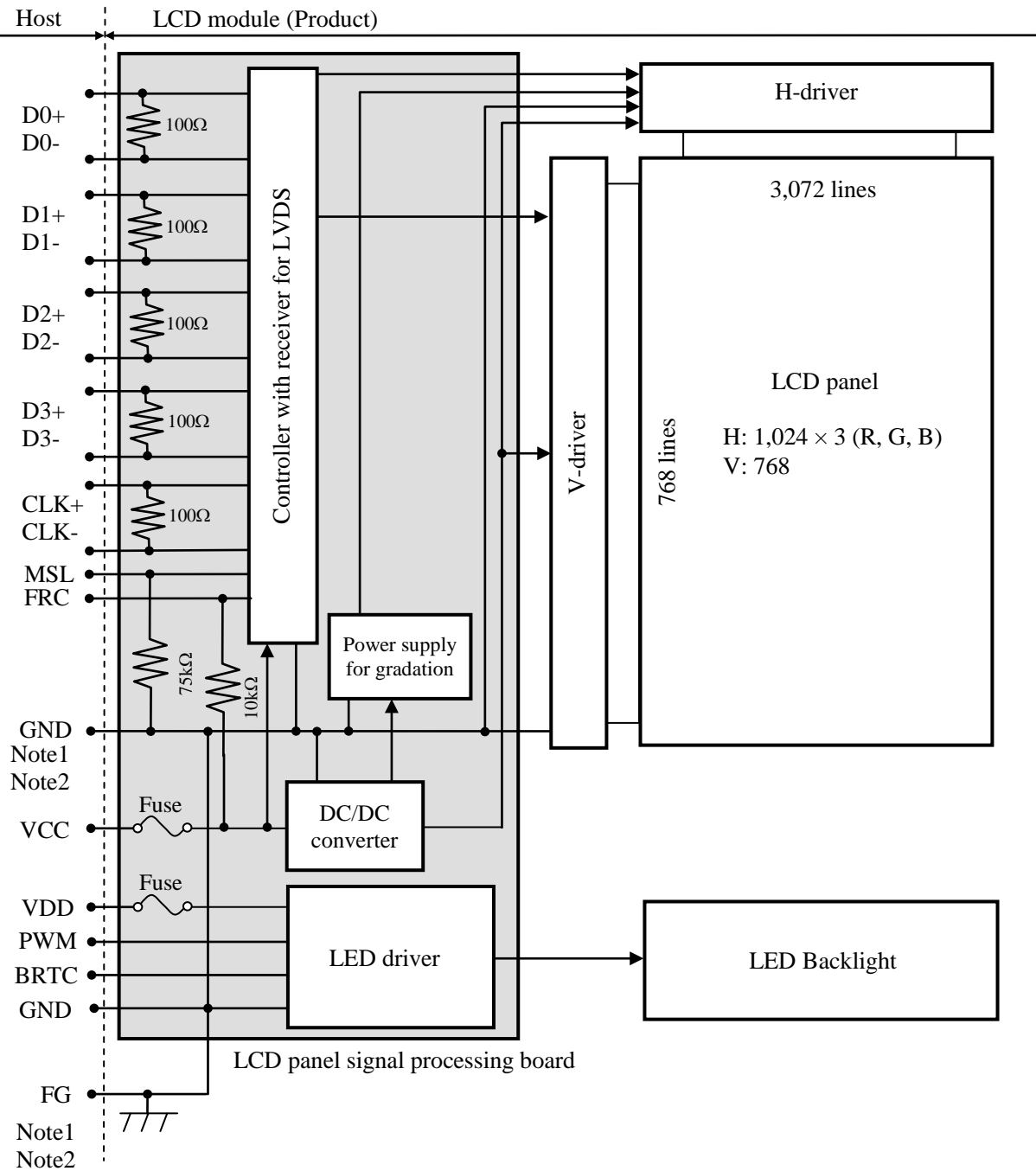

Note1: Relation between GND (Signal ground and LED driver ground) and FG (Frame ground) in the LCD module is as follows.

GND- FG	Connected
---------	-----------

Note2: GND and FG must be connected to customer equipment's ground, and it is recommended that these grounds to be connected together in customer equipment.



**4. DETAILED SPECIFICATIONS**
**4.1 MECHANICAL SPECIFICATIONS**

Parameter	Specification	Unit
Module size	326.5 ± 0.5 (W) × 253.5 ± 0.5 (H) × 11.8 ± 0.3 (D) Note1	mm
Display area	304.128 (H) × 228.096 (V) Note1	mm
Weight	1,050 (typ.), 1,100 (max.)	g

Note1: See "8. OUTLINE DRAWINGS".

**4.2 ABSOLUTE MAXIMUM RATINGS**

Parameter		Symbol	Rating	Unit	Remarks	
Power supply voltage	LCD panel signal processing board	VCC	-0.3 to +4.0	V	Ta= 25°C	
	LED driver	VDD	-0.3 to +33.0			
Input voltage for signals	Display signals Note1	VD	-0.3 to +1.98	V		
	Function signals Note2	VF	-0.3 to +4.0	V		
	Function signal for LED driver	PWM	-0.3 to +5.5	V		
		BRTC	-0.3 to +5.5	V		
Incident light intensity		II	150,000	lx		Note3
Storage temperature		Tst	-30 to +80	°C		-
Operating temperature	Front surface	TopF	-20 to +70	°C	Note4	
	Rear surface	TopR	-20 to +70	°C	Note5	
Relative humidity Note6		RH	≤ 95	%	Ta ≤ 40°C	
			≤ 85	%	40°C < Ta ≤ 50°C	
			≤ 55	%	50°C < Ta ≤ 60°C	
			≤ 36	%	60°C < Ta ≤ 70°C	
Absolute humidity Note6		AH	≤ 70 Note7	g/m <sup>3</sup>	Ta > 70°C	

Note1: D0+/-, D1+/-, D2+/-, D3+/-, CLK+/-

Note2: MSL, FRC

Note3: If the product surface (polarizer) is exposed to an ultraviolet ray, the polarizer may discolor (Surface treatment may be damaged.). Use a filter to protect the polarizer from the ultraviolet ray.

Note4: Measured at LCD panel surface (including self-heat)

Note5: Measured at LCD module's rear shield surface (including self-heat)

Note6: No condensation

Note7: Water amount at Ta= 70°C and RH= 36%

### 4.3 ELECTRICAL CHARACTERISTICS

#### 4.3.1 LCD panel signal processing board

(Ta= 25°C)

Parameter	Symbol	min.	typ.	max.	Unit	Remarks	
Power supply voltage	VCC	3.0	3.3	3.6	V	-	
Power supply current	ICC	-	400 Note1	840 Note2	mA	at VCC= 3.3V	
Permissible ripple voltage	VRPC	-	-	300	mVp-p	for VCC	
Differential input threshold voltage	High	VTH	-	-	+100	mV	at VCM= 1.25V Note3
	Low	VTL	-100	-	-	mV	
Terminating resistance	RT	-	100	-	Ω	-	
Input voltage for MSL and FRC signals	High	VFH	1.65	-	VCC	V	-
	Low	VFL	0	-	0.40	V	
Input current for MSL and FRC signals	High	IFH	-	-	10	μA	-
	Low	IFL	-10	-	-	μA	

Note1: Checkered flag pattern [by IEC 61747-6]

Note2: Pattern for maximum current

Note3: Common mode voltage for LVDS receiver



#### 4.3.2 LED driver

(Ta= 25°C)

Parameter	Symbol	min.	typ.	max.	Unit	Remarks	
Power supply voltage	VDD	10.8	12.0	12.6	V	Note1	
Power supply current	IDD	-	880	1,210 Note2	mA	At the maximum luminance control	
Permissible ripple voltage	VRPD	-	-	200	mVp-p	for VDD Note3	
Input voltage for PWM signal	High	VDFH1	1.2	-	5.5	V	-
	Low	VDFL1	-	-	0.35	V	
Input voltage for BRTC signal	High	VDFH2	1.5	-	5.5	V	-
	Low	VDFL2	0	-	0.8	V	
PWM frequency	f <sub>PWM</sub>	200	-	1k	Hz	Note4, Note5	
PWM duty ratio	DR <sub>PWM</sub>	1	-	100	%	Note6, Note7	
PWM pulse width	t <sub>PWH</sub>	5	-	-	μs		

Note1: When designing of the power supply, take the measures for the prevention of surge voltage.

Note2: This value excludes peak current such as overshoot current.

Note3: The power supply lines (VDD and GND) may have ripple voltage during luminance control of LED. There is the possibility that the ripple voltage produces acoustic noise and signal wave noise in audio circuit and so on.



Note4: A recommended  $f_{PWM}$  value is as follows.

$$f_{PWM} = \frac{2n-1}{4} \times fv$$

(n = integer, fv = frame frequency of LCD module)

Note5: Depending on the frequency used, so noise may appear on the screen, please conduct a thorough evaluation.

Note6: While the BRTC signal is high, do not set the tPWH (PWM pulse width) is less than 5 $\mu$ s. It may cause abnormal working of the backlight. In this case, turn the backlight off and then on again by BRTC signal.

Note7: Regardless of the PWM frequency, both PWM duty ratio and PWM pulse width must be always more than the minimum values.

#### 4.3.3 Power supply voltage ripple

This product works, even if the ripple voltage levels are over the permissible values as the following table, but there might be noise on the display image.

Power supply voltage		Ripple voltage (Measure at input terminal of power supply)	Note1	Unit
VCC	3.3V	$\leq 300$		mVp-p
VDD	12.0V	$\leq 200$		mVp-p

Note1: The permissible ripple voltage includes spike noise.

#### 4.3.4 Fuse

Parameter	Fuse		Rating	Fusing current	Remarks
	Type	Supplier			
VCC	FCC16152AB	KAMAYA ELECTRIC Co., Ltd.	1.5A	3.0A	Note1
			36V		
VDD	FCC16202AB	KAMAYA ELECTRIC Co., Ltd.	2.0A	4.0A	
			36V		

Note1: The power supply's rated current must be more than the fusing current. If it is less than the fusing current, the fuse may not blow in a short time, and then nasty smell, smoke and so on may occur.

4.4 POWER SUPPLY VOLTAGE SEQUENCE

4.4.1 LCD panel signal processing board

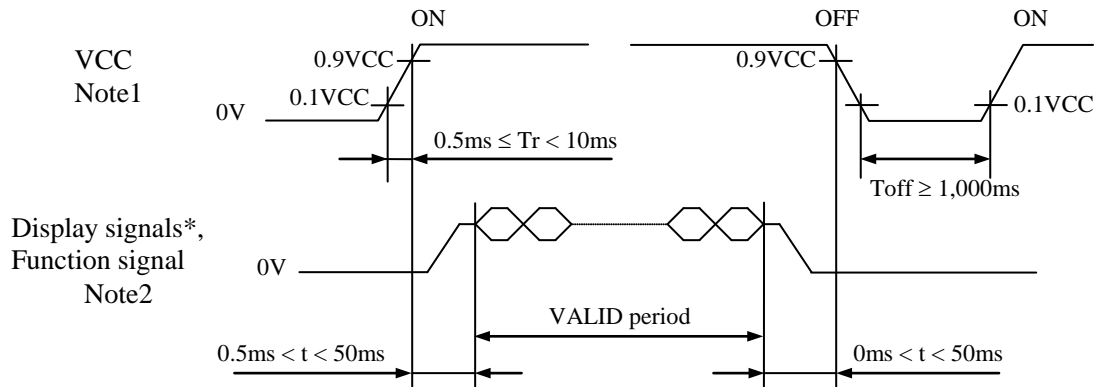

\* These signals should be measured at the terminal of 100Ω resistance.

Note1: If there is a voltage variation (voltage drop) at the rising edge of VCC below 3.0V, there is a possibility that a product does not work due to a protection circuit.

Note2: Display signals (D0+/-, D1+/-, D2+/-, D3+/- and CLK+/-) and function signal (MSL, FRC) must be set to Low or High-impedance, except the VALID period (See above sequence diagram), in order to avoid the circuitry damage.

If some of display and function signals of this product are cut while this product is working, even if the signal input to it once again, it might not work normally. If a customer stops the display and function signals, VCC also must be shut down.

4.4.2 LED driver

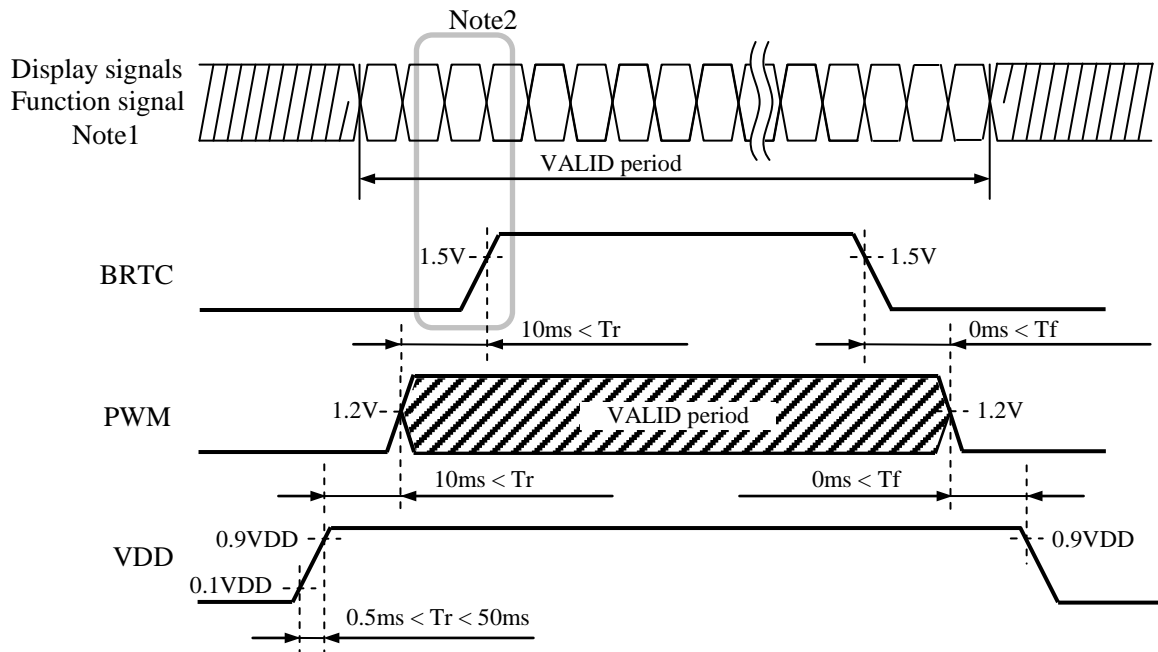

Note1: These are the display and function signals for LCD panel signal processing board.

Note2: The backlight should be turned on within the valid period of display and function signals, in order to avoid unstable data display.

**4.5 CONNECTIONS AND FUNCTIONS FOR INTERFACE PINS**
**4.5.1 LCD panel signal processing board**

CN1 socket (LCD module side): 185083-20121 (P-TWO ELECTRIC TECHNOLOGY CO., LTD.)  
 Adaptable plug: DF14-20S-1.25C (Hirose Electric Co., Ltd. (HRS))

Pin No.	Symbol	Signal	Input data signal: 8-bit		Input data signal: 6-bit	Remarks
			MAP A	MAP B		
1	VCC	Power supply	Power supply			Note1
2	VCC					
3	GND	Ground	Ground			Note1
4	GND					
5	D0-	Pixel data	R2-R7,G2	R0-R5,G0		Note2
6	D0+					
7	GND	Ground	Ground			Note1
8	D1-	Pixel data	G3-G7,B2-B3	G1-G5,B0-B1		Note2
9	D1+					
10	GND	Ground	Ground			Note1
11	D2-	Pixel data	B4-B7,DE	B2-B5,DE		Note2
12	D2+					
13	GND	Ground	Ground			Note1
14	CLK-	Pixel clock	Pixel clock			Note2
15	CLK+					
16	GND	Ground	Ground			Note1
17	D3- / GND	Pixel data / Ground	R0-R1 G0-G1 B0-B1	R6-R7 G6-G7 B6-B7	Ground	Note2
18	D3+ / GND					
19	MSL	Selection of LVDS Input data map	High	Low or Open	High	Note3 Note4
20	FRC	Selection of the number of colors	Low		High or Open	-

Note1: All GND and VCC terminals should be used without any non-connected lines.

Note2: Twist pair wires with 100Ω (Characteristic impedance) should be used between LCD panel signal processing board and LVDS transmitter.

Note3: See "**4.5.4 Connection between receiver and transmitter for LVDS**".

Note4: See "**4.6 DISPLAY COLORS AND INPUT DATA SIGNALS**".

4.5.2 LED driver

CN2 socket (LCD module side): MSB24038P6 (STM)

Adaptable plug: P24038P6 (STM) or 51146-0600 (Molex)

Pin No.	Symbol	Signal	Remarks
1	PWM	Luminance control	PWM Dimming
2	BRTC	Back light ON/OFF control	High: On / Low: Off
3	GND	Ground	-
4	GND	Ground	-
5	VDD	Power supply	-
6	VDD	Power supply	-

4.5.3 Positions of socket

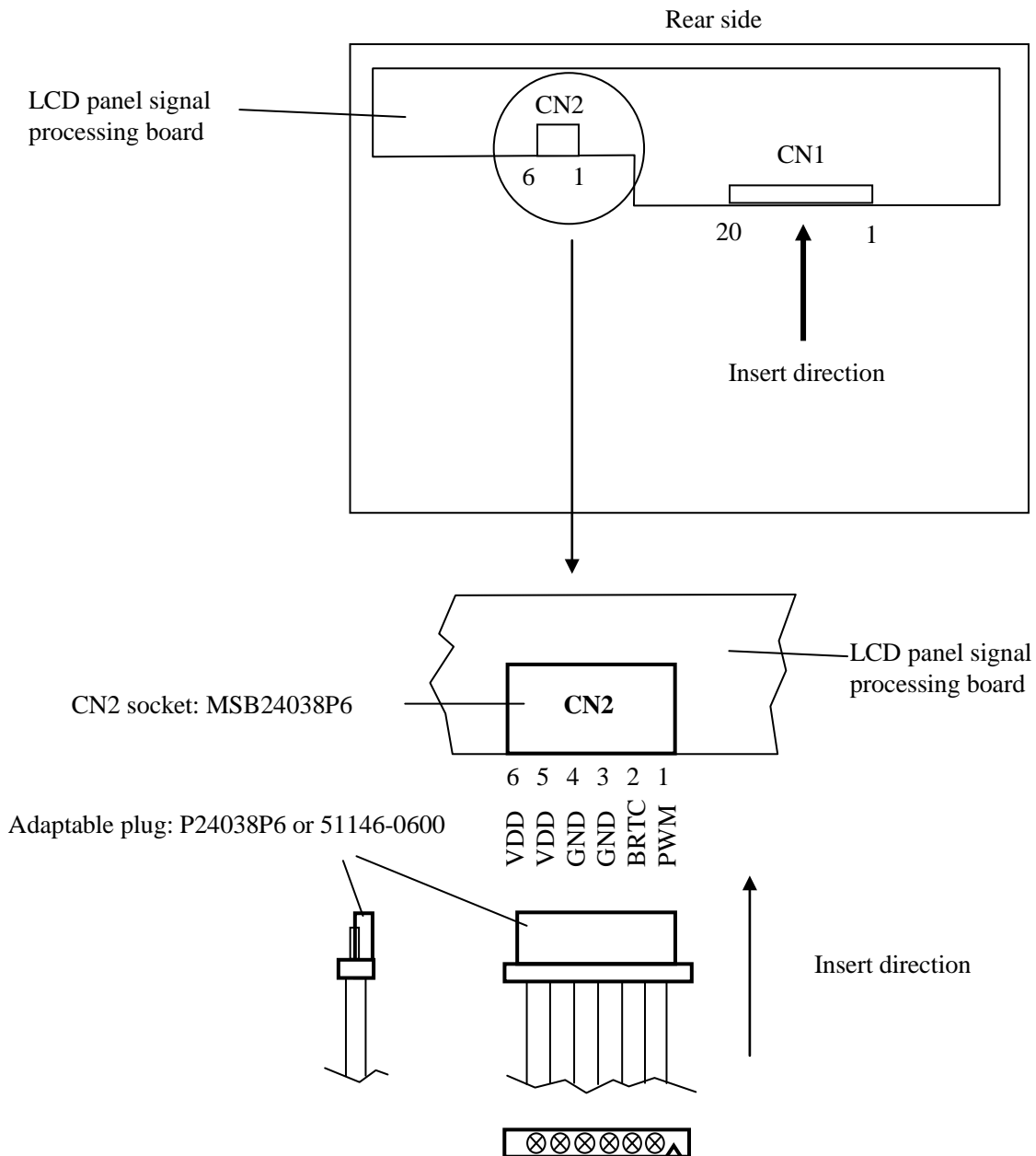

4.5.4 Connection between receiver and transmitter for LVDS  
 (1) Input data signal: 8-bit, MAP A (FRC: Low, MSL: High)

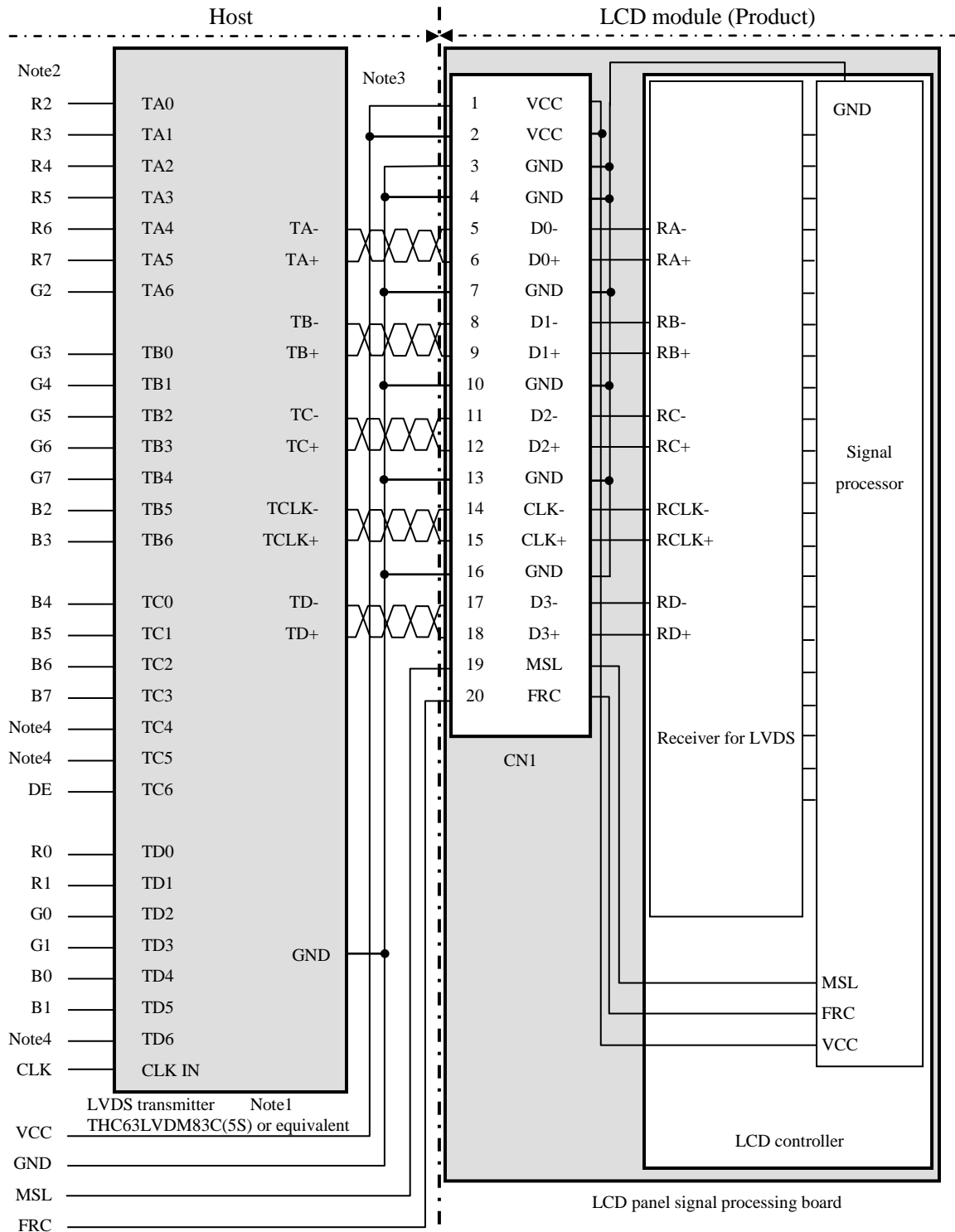

Note1: Recommended transmitter: THC63LVDM83C(5S) (THine Electronics Inc.) or equivalent

Note2: LSB (Least Significant Bit) - R0, G0, B0 MSB (Most Significant Bit) - R7, G7, B7

Note3: Twist pair wires with 100Ω (Characteristic impedance) should be used between LCD panel signal processing board and LVDS transmitter.

Note4: Input signals to TC4, TC5 and TD6 are not used inside the product, but do not keep them open to avoid noise problem.

(2) Input data signal: 8-bit, MAP B (FRC: Low, MSL: Low or Open)

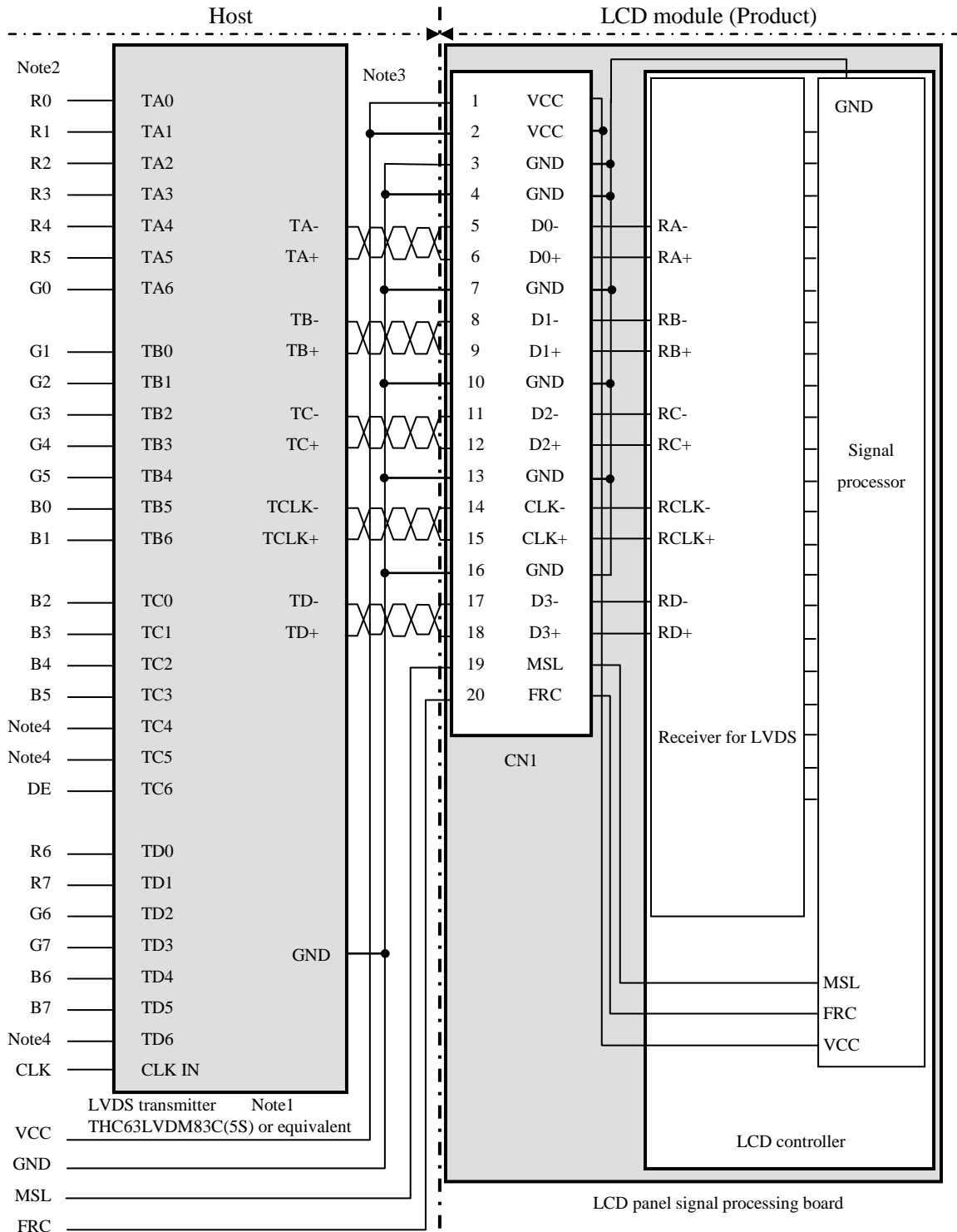

Note1: Recommended transmitter: THC63LVDM83C(5S) (THine Electronics Inc.) or equivalent

Note2: LSB (Least Significant Bit) - R0, G0, B0 MSB (Most Significant Bit) - R7, G7, B7

Note3: Twist pair wires with 100Ω (Characteristic impedance) should be used between LCD panel signal processing board and LVDS transmitter.

Note4: Input signals to TC4, TC5 and TD6 are not used inside the product, but do not keep them open to avoid noise problem.





4.5.5 Input data mapping

(1) Input data signal: 8-bit, MAP A

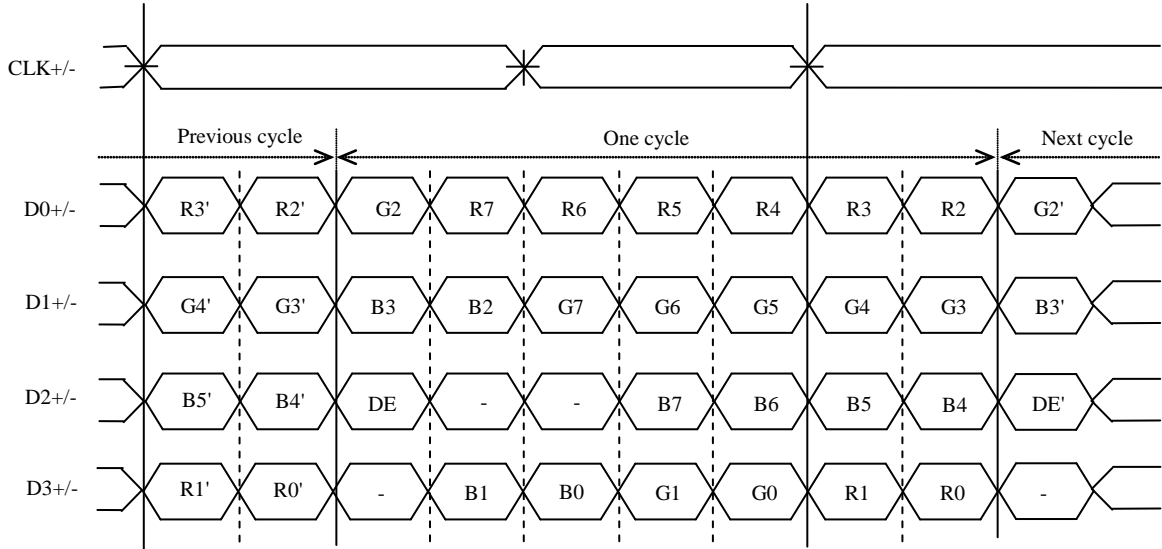

Note1: LSB (Least Significant Bit) – R0, G0, B0 MSB (Most Significant Bit) – R7, G7, B7

Note2: Twist pair wires with 100Ω(Characteristic impedance) should be used between LCD panel signal processing board and LVDS transmitter.



(2) Input data signal: 8-bit, MAP B

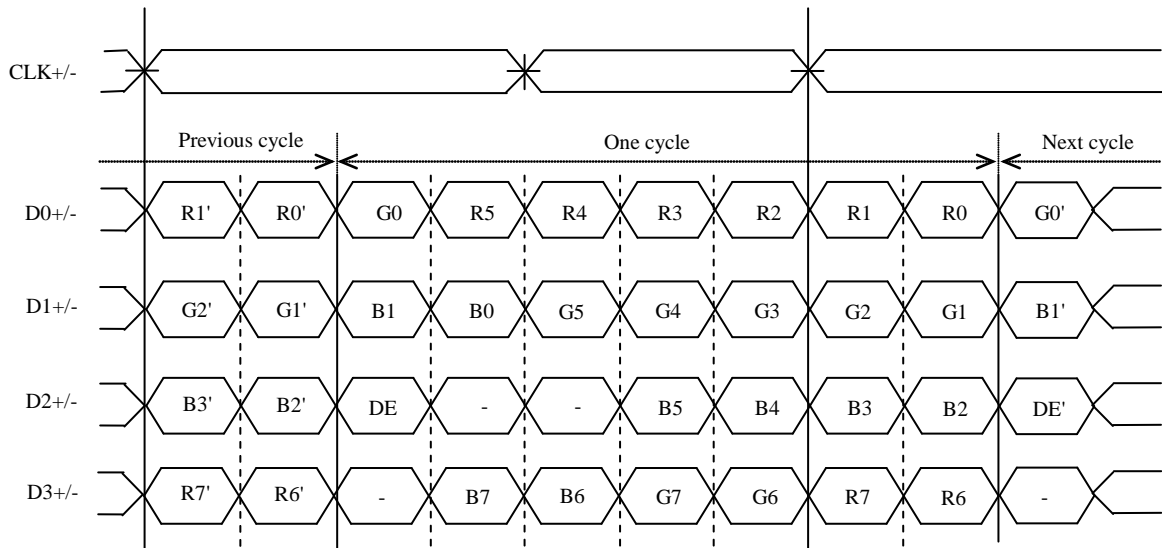

Note1: LSB (Least Significant Bit) – R0, G0, B0 MSB (Most Significant Bit) – R7, G7, B7

Note2: Twist pair wires with 100Ω(Characteristic impedance) should be used between LCD panel signal processing board and LVDS transmitter.



(3) Input data signal: 6-bit

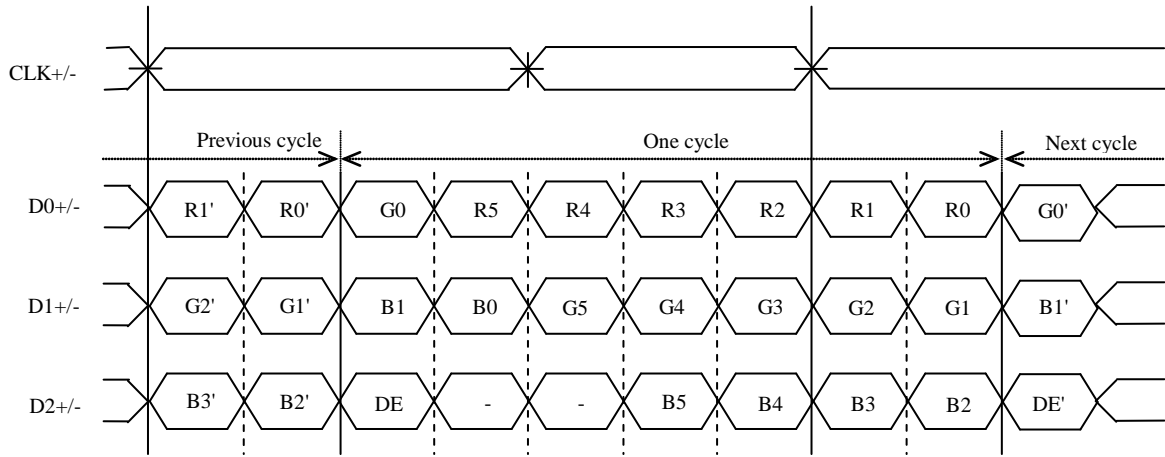

Note1: LSB (Least Significant Bit) – R0, G0, B0 MSB (Most Significant Bit) – R5, G5, B5

Note2: Twist pair wires with 100Ω(Characteristic impedance) should be used between LCD panel signal processing board and LVDS transmitter.



4.6 DISPLAY COLORS AND INPUT DATA SIGNALS

4.6.1 Combinations of input data signals, FRC and MSL signal

This product can display equivalent of 16,777,216 colors and 262,144 colors by combination of input data signals, FRC and MSL signal. See the following table.

Combination	Input data signals	Input Data mapping	CN1- Pin No.17 and 18	FRC terminal	MSL terminal	Display colors	Remarks
①	8-bit	MAP A	D3+/-	Low	High	16,777,216	Note1
②	8-bit	MAP B	D3+/-	Low	Low or Open	16,777,216	Note1
③	6-bit	-	GND	High or Open	High	262,144	Note2

Note1: See "4.6.2 16,777,216 colors".

Note2: See "4.6.3 262,144 colors".

4.6.2 16,777,216 colors

This product can display equivalent of 16,777,216 colors in 256 gray scales by combination ① or ②.  
(See "4.6.1 Combinations of input data signals, FRC and MSL signal".)

Also the relation between display colors and input data signals is as the following table.

Display colors		Data signal (0: Low level, 1: High level)																							
		R7	R6	R5	R4	R3	R2	R1	R0	G7	G6	G5	G4	G3	G2	G1	G0	B7	B6	B5	B4	B3	B2	B1	B0
Basic Colors	Black	0	0	0	0	0	0	0	0	0	0	0	0	0	0	0	0	0	0	0	0	0	0	0	0
	Blue	0	0	0	0	0	0	0	0	0	0	0	0	0	0	0	0	1	1	1	1	1	1	1	1
	Red	1	1	1	1	1	1	1	1	0	0	0	0	0	0	0	0	0	0	0	0	0	0	0	0
	Magenta	1	1	1	1	1	1	1	1	0	0	0	0	0	0	0	0	1	1	1	1	1	1	1	1
	Green	0	0	0	0	0	0	0	0	1	1	1	1	1	1	1	1	0	0	0	0	0	0	0	0
	Cyan	0	0	0	0	0	0	0	0	1	1	1	1	1	1	1	1	1	1	1	1	1	1	1	1
	Yellow	1	1	1	1	1	1	1	1	1	1	1	1	1	1	1	1	0	0	0	0	0	0	0	0
	White	1	1	1	1	1	1	1	1	1	1	1	1	1	1	1	1	1	1	1	1	1	1	1	1
Red gray scale	Black	0	0	0	0	0	0	0	0	0	0	0	0	0	0	0	0	0	0	0	0	0	0	0	0
	dark	0	0	0	0	0	0	0	1	0	0	0	0	0	0	0	0	0	0	0	0	0	0	0	0
	↑																								
	↓																								
	bright	1	1	1	1	1	1	0	1	0	0	0	0	0	0	0	0	0	0	0	0	0	0	0	0
Red	1	1	1	1	1	1	1	1	0	0	0	0	0	0	0	0	0	0	0	0	0	0	0	0	
Green gray scale	Black	0	0	0	0	0	0	0	0	0	0	0	0	0	0	0	0	0	0	0	0	0	0	0	0
	dark	0	0	0	0	0	0	0	0	0	0	0	0	0	0	0	1	0	0	0	0	0	0	0	0
	↑																								
	↓																								
	bright	0	0	0	0	0	0	0	0	1	1	1	1	1	1	0	1	0	0	0	0	0	0	0	0
Green	0	0	0	0	0	0	0	0	1	1	1	1	1	1	1	1	0	0	0	0	0	0	0	0	
Blue gray scale	Black	0	0	0	0	0	0	0	0	0	0	0	0	0	0	0	0	0	0	0	0	0	0	0	0
	dark	0	0	0	0	0	0	0	0	0	0	0	0	0	0	0	0	0	0	0	0	0	0	0	1
	↑																								
	↓																								
	bright	0	0	0	0	0	0	0	0	0	0	0	0	0	0	0	0	1	1	1	1	1	1	0	1
Blue	0	0	0	0	0	0	0	0	0	0	0	0	0	0	0	0	1	1	1	1	1	1	1	1	

4.6.3 262,144 colors

This product can display 262,144 colors with 64 gray scales by combination ③.

(See "4.6.1 Combinations of input data signals, FRC and MSL signal".)

Also the relation between display colors and input data signals is as follows.

Display colors		Data signal (0: Low level, 1: High level)																	
		R5	R4	R3	R2	R1	R0	G5	G4	G3	G2	G1	G0	B5	B4	B3	B2	B1	B0
Basic colors	Black	0	0	0	0	0	0	0	0	0	0	0	0	0	0	0	0	0	0
	Blue	0	0	0	0	0	0	0	0	0	0	0	0	1	1	1	1	1	1
	Red	1	1	1	1	1	1	0	0	0	0	0	0	0	0	0	0	0	0
	Magenta	1	1	1	1	1	1	0	0	0	0	0	0	1	1	1	1	1	1
	Green	0	0	0	0	0	0	1	1	1	1	1	1	0	0	0	0	0	0
	Cyan	0	0	0	0	0	0	1	1	1	1	1	1	1	1	1	1	1	1
	Yellow	1	1	1	1	1	1	1	1	1	1	1	1	0	0	0	0	0	0
	White	1	1	1	1	1	1	1	1	1	1	1	1	1	1	1	1	1	1
Red gray scale	Black	0	0	0	0	0	0	0	0	0	0	0	0	0	0	0	0	0	0
	dark	0	0	0	0	0	1	0	0	0	0	0	0	0	0	0	0	0	0
	↑																		
	↓																		
	bright	1	1	1	1	0	1	0	0	0	0	0	0	0	0	0	0	0	0
	Red	1	1	1	1	1	1	0	0	0	0	0	0	0	0	0	0	0	0
Green gray scale	Black	0	0	0	0	0	0	0	0	0	0	0	0	0	0	0	0	0	0
	dark	0	0	0	0	0	0	0	0	0	0	1	0	0	0	0	0	0	0
	↑																		
	↓																		
	bright	0	0	0	0	0	0	1	1	1	1	0	1	0	0	0	0	0	0
	Green	0	0	0	0	0	0	1	1	1	1	1	1	0	0	0	0	0	0
Blue gray scale	Black	0	0	0	0	0	0	0	0	0	0	0	0	0	0	0	0	0	0
	dark	0	0	0	0	0	0	0	0	0	0	0	0	0	0	0	0	1	0
	↑																		
	↓																		
	bright	0	0	0	0	0	0	0	0	0	0	0	0	1	1	1	1	0	1
	Blue	0	0	0	0	0	0	0	0	0	0	0	0	1	1	1	1	1	1

4.7 DISPLAY POSITIONS

The following table is the coordinates per pixel.

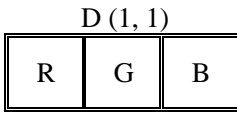

D( 1, 1)	D( 2, 1)	...	D( X, 1)	...	D(1,023, 1)	D(1024, 1)
D( 1, 2)	D( 2, 2)	...	D( X, 2)	...	D(1,023, 2)	D(1024, 2)
.	.	.	.	.	.	.
.	.	...	.	...	.	...
.	.	.	.	.	.	.
D( 1, Y)	D( 2, Y)	...	D( X, Y)	...	D(1,023, Y)	D(1024, Y)
.	.	.	.	.	.	.
.	.	...	.	...	.	.
.	.	.	.	.	.	.
D( 1, 767)	D( 2, 767)	...	D( X, 767)	...	D(1,023, 767)	D(1024, 767)
D( 1, 768)	D( 2, 768)	...	D( X, 768)	...	D(1,023, 768)	D(1024, 768)

4.8 INPUT SIGNAL TIMINGS

4.8.1 Outline of input signal timings

- Horizontal signal

Note1

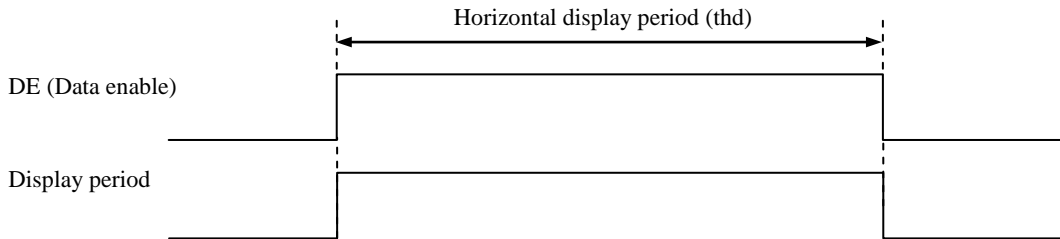

- Vertical signal

Note1

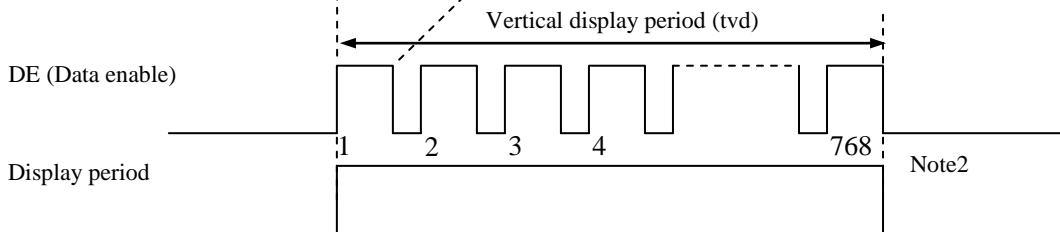

Note1: This diagram indicates virtual signal for set up to timing.

Note2: See "4.8.3 Input signal timing chart" for the pulse number.

## 4.8.2 Timing characteristics

(Note1, Note2, Note3)

Parameter		Symbol	min.	typ.	max.	Unit	Remarks	
CLK	Frequency	1/tc	50.0	65.0	81.25	MHz	15.385ns (typ.)	
	Duty ratio	-	-			-	-	
	Rise time, Fall time	-				ns		
DATA	CLK-DATA	Setup time	-			ns	-	
		Hold time				ns		
	Rise time, Fall time	-				ns		
DE	Horizontal	Cycle	th	16.542	20.676	26.88	μs	48.363kHz (typ.)
		Display period	thd	1,100	1,344	1,800	CLK	
	Vertical (One frame)	Cycle	tv	13.34	16.666	20.0	ms	60.0Hz (typ.)
			Display period	tvd	780	806	1,334	
		Display period	tvd	768			H	-
	CLK-DE	Setup time	-	-			ns	-
		Hold time	-				ns	
Rise time, Fall time	-	ns						

Note1: Definition of parameters is as follows.

$$tc = 1CLK, th = 1H$$

Note2: See the data sheet of LVDS transmitter.

Note3: Vertical cycle (tv) should be specified in integral multiple of Horizontal cycle (th).



4.8.3 Input signal timing chart



Horizontal timing

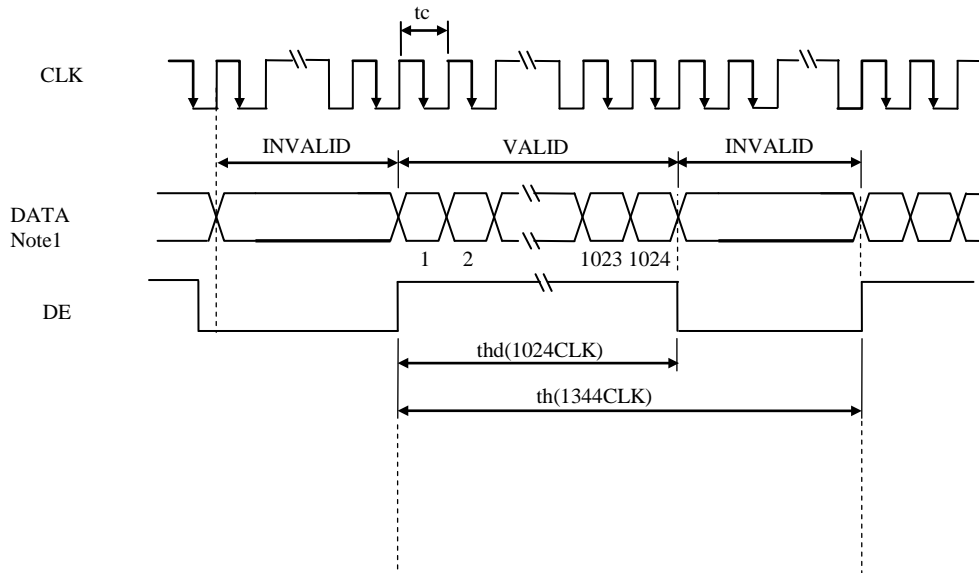

Vertical timing

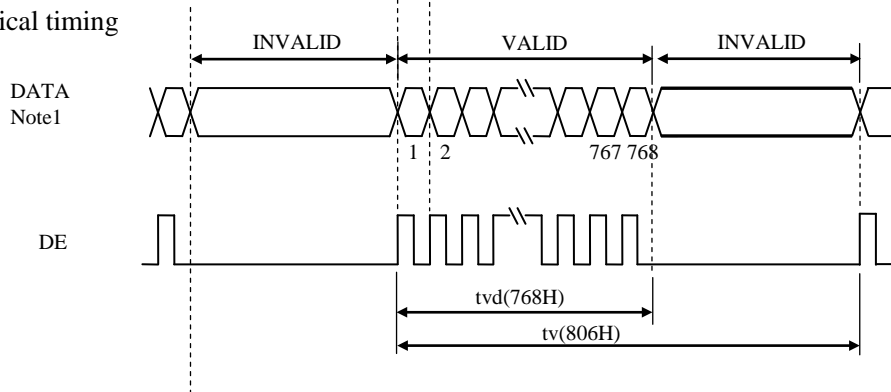

Note1: DATA = R0-R7, G0-G7, B0-B7 or R0-R5, G0-G5, B0-B5



4.9 OPTICS

4.9.1 Optical characteristics

(Note1, Note2)

Parameter	Condition	Symbol	min.	typ.	max.	Unit	Measuring instrument	Remarks	
Luminance	White at center $\theta_R=0^\circ, \theta_L=0^\circ, \theta_U=0^\circ, \theta_D=0^\circ$	L	450	600	-	cd/m <sup>2</sup>	BM-5A	-	
Contrast ratio	White/Black at center $\theta_R=0^\circ, \theta_L=0^\circ, \theta_U=0^\circ, \theta_D=0^\circ$	CR	400	600	-	-	BM-5A	Note3	
Luminance uniformity	White $\theta_R=0^\circ, \theta_L=0^\circ, \theta_U=0^\circ, \theta_D=0^\circ$	LU	-	1.25	1.33	-	BM-5A	Note4	
Chromaticity	White	x coordinate	W <sub>x</sub>	0.263	0.313	0.363	-	SR-3	Note5
		y coordinate	W <sub>y</sub>	0.279	0.329	0.379	-		
	Red	x coordinate	R <sub>x</sub>	-	0.631	-	-		
		y coordinate	R <sub>y</sub>	-	0.357	-	-		
	Green	x coordinate	G <sub>x</sub>	-	0.344	-	-		
		y coordinate	G <sub>y</sub>	-	0.608	-	-		
Blue	x coordinate	B <sub>x</sub>	-	0.153	-	-			
	y coordinate	B <sub>y</sub>	-	0.089	-	-			
Color gamut	$\theta_R=0^\circ, \theta_L=0^\circ, \theta_U=0^\circ, \theta_D=0^\circ$ at center, against NTSC color space	C	55	60	-	%			
Response time	White to Black	T <sub>on</sub>	-	3	5	ms	BM-5A -10000	Note6	
	Black to White	T <sub>off</sub>	-	5	8	ms		Note7	
Viewing angle	Right	$\theta_U=0^\circ, \theta_D=0^\circ, CR \geq 10$	$\theta_R$	70	80	-	BM-5A or EZ Contrast	Note8	
	Left	$\theta_U=0^\circ, \theta_D=0^\circ, CR \geq 10$	$\theta_L$	70	80	-			
	Up	$\theta_R=0^\circ, \theta_L=0^\circ, CR \geq 10$	$\theta_U$	70	80	-			
	Down	$\theta_R=0^\circ, \theta_L=0^\circ, CR \geq 10$	$\theta_D$	70	80	-			

Note1: These are initial characteristics.

Note2: Measurement conditions are as follows.

T<sub>a</sub>= 25°C, VCC= 3.3V, VDD= 12.0V, PWM duty ratio: 100%,

Display mode: XGA, Horizontal cycle= 1/48.363kHz, Vertical cycle= 1/60.0Hz,

FRC= Low (8-bit mode)

Optical characteristics are measured at luminance saturation 20minutes after the product works, in the dark room. Also measurement methods are as follows.

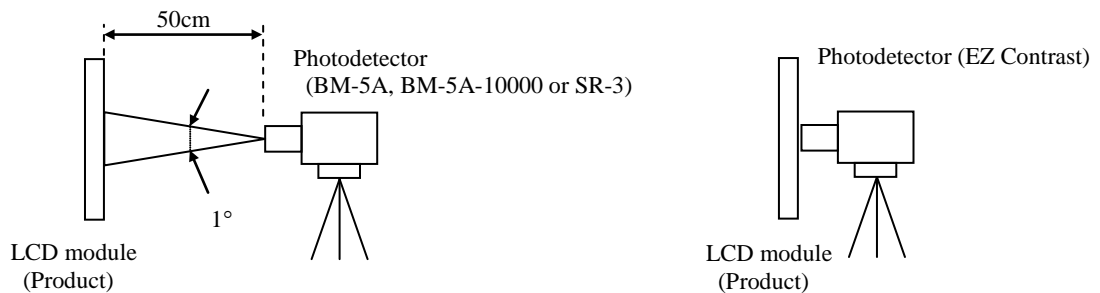

Note3: See "4.9.2 Definition of contrast ratio".

Note4: See "4.9.3 Definition of luminance uniformity".

Note5: These coordinates are found on CIE 1931 chromaticity diagram.

Note6: Product surface temperature: TopF= 30°C

Note7: See "4.9.4 Definition of response times".

Note8: See "4.9.5 Definition of viewing angles".

4.9.2 Definition of contrast ratio

The contrast ratio is calculated by using the following formula.

$$\text{Contrast ratio (CR)} = \frac{\text{Luminance of white screen}}{\text{Luminance of black screen}}$$

4.9.3 Definition of luminance uniformity

The luminance uniformity is calculated by using following formula.

$$\text{Luminance uniformity (LU)} = \frac{\text{Maximum luminance from ① to ⑨}}{\text{Minimum luminance from ① to ⑨}}$$

The luminance is measured at near the 9 points shown below.

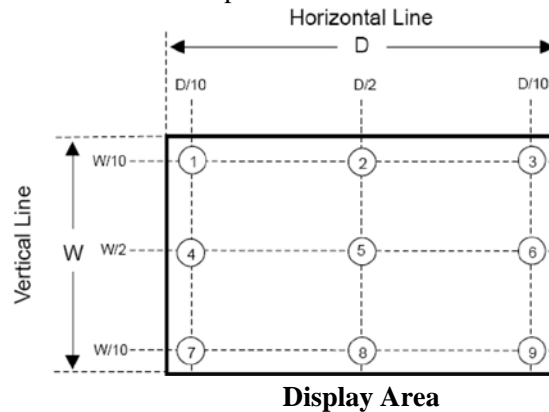

4.9.4 Definition of response times

Response time is measured at the time when the luminance changes from "white" to "black", or "black" to "white" on the same screen point, by photo-detector. Ton is the time when the luminance changes from 90% down to 10%. Also Toff is the time when the luminance changes from 10% up to 90% (See the following diagram.).

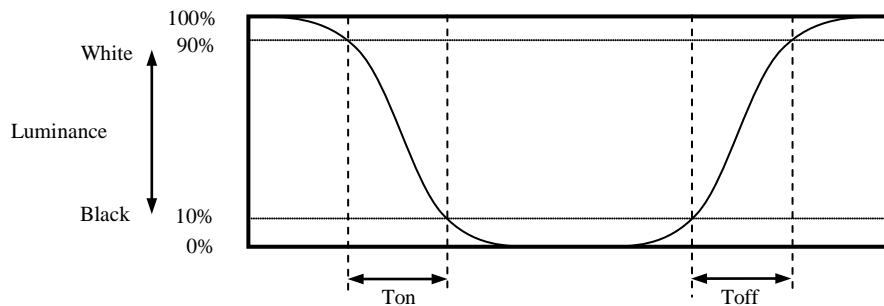

4.9.5 Definition of viewing angles

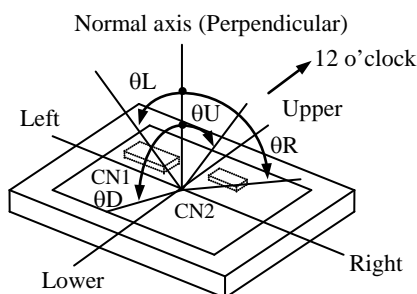

**5. ESTIMATED LUMINANCE LIFETIME**

The luminance lifetime is the time from initial luminance to half-luminance.

**This lifetime is the estimated value, and is not guarantee value.**

Condition		Estimated luminance lifetime (Life time expectancy) Note1, Note2, Note3	Unit
LED elementary substance	25°C (Ambient temperature of the product) Continuous operation, PWM duty ratio: 100%	70,000	h
	70°C (Ambient temperature of the product) Continuous operation, PWM duty ratio: 100%	60,000	h

Note1: Life time expectancy is mean time to half-luminance.

Note2: Estimated luminance lifetime is not the value for LCD module but the value for LED elementary substance.

Note3: By ambient temperature, the lifetime changes particularly. Especially, in case the product works under high temperature environment, the lifetime becomes short.

## 6. RELIABILITY TESTS

Test item	Condition	Judgment	Note1
High temperature and humidity (Operation)	① $60 \pm 2^{\circ}\text{C}$ , RH= 90%, 240hours ② Display data is black.	No display malfunctions	
High temperature (Operation)	① $70 \pm 3^{\circ}\text{C}$ , 240hours ② Display data is black.		
Heat cycle (Operation)	① $-20 \pm 3^{\circ}\text{C} \dots 1\text{hour}$ $70 \pm 3^{\circ}\text{C} \dots 1\text{hour}$ ② 50cycles, 4 hours/cycle ③ Display data is Black.		
Thermal shock (Non operation)	① $-30 \pm 3^{\circ}\text{C} \dots 30\text{minutes}$ $80 \pm 3^{\circ}\text{C} \dots 30\text{minutes}$ ② 100cycles, 1hour/cycle ③ Temperature transition time is within 5 minutes.		
ESD (Operation)	① 150pF, 150 $\Omega$ , $\pm 15\text{kV}$ ② 9 places on a panel surface Note2 ③ 10 times each place at 1 sec interval		
Dust (Operation)	① Sample dust: No. 15 (by JIS-Z8901) ② 15 seconds stir ③ 8 times repeat at 1 hour interval		
Vibration (Non operation)	① 5 to 100Hz, 11.76m/s <sup>2</sup> ② 1 minute/cycle ③ X, Y, Z directions ④ 50 times each direction		
Mechanical shock (Non operation)	① 294m/s <sup>2</sup> , 11ms ② $\pm X$ , $\pm Y$ , $\pm Z$ directions ③ 3 times each direction		

Note1: Display and appearance are checked under environmental conditions equivalent to the inspection conditions of defect criteria.

Note2: See the following figure for discharge points.

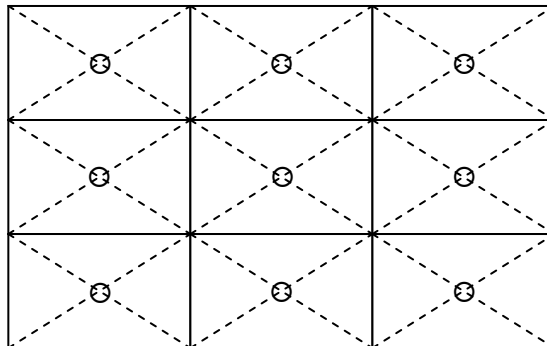

## 7. PRECAUTIONS

### 7.1 MEANING OF CAUTION SIGNS

The following caution signs have very important meaning. **Be sure to read "7.2 CAUTIONS" and "7.3 ATTENTIONS"!**



This sign has the meaning that a customer will be injured or the product will sustain damage if the customer practices wrong operations.



This sign has the meaning that a customer will be injured if the customer practices wrong operations.

### 7.2 CAUTIONS



**\* Do not shock and press the LCD panel and the backlight! There is a danger of breaking, because they are made of glass. (Shock: Equal to or no greater than  $294\text{m/s}^2$  and equal to or no greater than 11ms, Pressure: Equal to or no greater than 19.6 N ( $\phi 16\text{mm}$  jig))**

### 7.3 ATTENTIONS



#### 7.3.1 Handling of the product

- ① Take hold of both ends without touching the circuit board when the product (LCD module) is picked up from inner packing box to avoid broken down or misadjustment, because of stress to mounting parts on the circuit board.
- ② When the product is put on the table temporarily, display surface must be placed downward.
- ③ When handling the product, take the measures of electrostatic discharge with such as earth band, ionic shower and so on, because the product may be damaged by electrostatic.
- ④ The torque for product mounting screws must never exceed  $0.392\text{N}\cdot\text{m}$ . Higher torque might result in distortion of the bezel. And the length of product mounting screws must be  $\leq 4.5\text{mm}$ .
- ⑤ The product must be installed using mounting holes without undue stress such as bends or twist (See outline drawings). And do not add undue stress to any portion (such as bezel flat area). Bends or twist described above and undue stress to any portion may cause display mura.
- ⑥ Do not press or rub on the sensitive product surface. When cleaning the panel surface, wipe it with a soft dry cloth.
- ⑦ Do not push or pull the interface connectors while the product is working.
- ⑧ When handling the product, use of an original protection sheet on the product surface (polarizer) is recommended for protection of product surface. Adhesive type protection sheet may change color or characteristics of the polarizer.
- ⑨ Usually liquid crystals don't leak through the breakage of glasses because of the surface tension of thin layer and the construction of LCD panel. But, if you contact with liquid crystal by any chance, please wash it away with soap and water.

7.3.2 Environment

- ① Do not operate or store in high temperature, high humidity, dewdrop atmosphere or corrosive gases. Keep the product in packing box with antistatic pouch in room temperature to avoid dusts and sunlight, when storing the product.
- ② In order to prevent dew condensation occurred by temperature difference, the product packing box must be opened after enough time being left under the environment of an unpacking room. Evaluate the storage time sufficiently because dew condensation is affected by the environmental temperature and humidity. (Recommended leaving time: 6 hours or more with the original packing state after a customer receives the package)
- ③ Do not operate in high magnetic field. If not, circuit boards may be broken.
- ④ This product is not designed as radiation hardened.

7.3.3 Characteristics

**The following items are neither defects nor failures.**

- ① Characteristics of the LCD (such as response time, luminance, color uniformity and so on) may be changed depending on ambient temperature. If the product is stored under condition of low temperature for a long time, it may cause display mura. In this case, the product should be operated after enough time being left under condition of operating temperature.
- ② Display mura, flickering, vertical streams or tiny spots may be observed depending on display patterns.
- ③ Do not display the fixed pattern for a long time because it may cause image sticking. Use a screen saver, if the fixed pattern is displayed on the screen.
- ④ The display color may be changed depending on viewing angle because of the use of condenser sheet in the backlight.
- ⑤ Optical characteristics may be changed depending on input signal timings.
- ⑥ The product gives AR (antireflection) coating of the polarizer surface. Though AR (antireflection) coating actualizes the low reflection with the multilayer structure, the color of reflection may differ among products and the color change of reflection may occur in the same product by fluctuation of AR (antireflection) coating.

7.3.4 Others

- ① All GND, VCC and VDD terminals should be used without any non-connected lines.
- ② Do not disassemble a product or adjust variable resistors.
- ③ See "REPLACEMENT MANUAL FOR LAMP HOLDER SET", when replacing lamp holder set.
- ④ Pack the product with the original shipping package, in order to avoid any damages during transportation, when returning the product to TMJ.
- ⑤ The information of China RoHS (II) six hazardous substances or elements in this product is as follows. ☆

China RoHS (II) six hazardous substances or elements					
Lead (Pb)	Mercury (Hg)	Cadmium (Cd)	Hexavalent Chromium (Cr VI)	Polybrominated Biphenyls (PBB)	Polybrominated Biphenyl Ethers (PBDE)
×	○	○	○	○	○

Note1: ○: This indicates that the poisonous or harmful material in all the homogeneous materials for this part is equal or below the limitation level of GB/T26572-2011 standard regulation.

×: This indicates that the poisonous or harmful material in all the homogeneous materials for this part is above the limitation level of GB/T26572-2011 standard regulation.





8.2 REAR VIEW

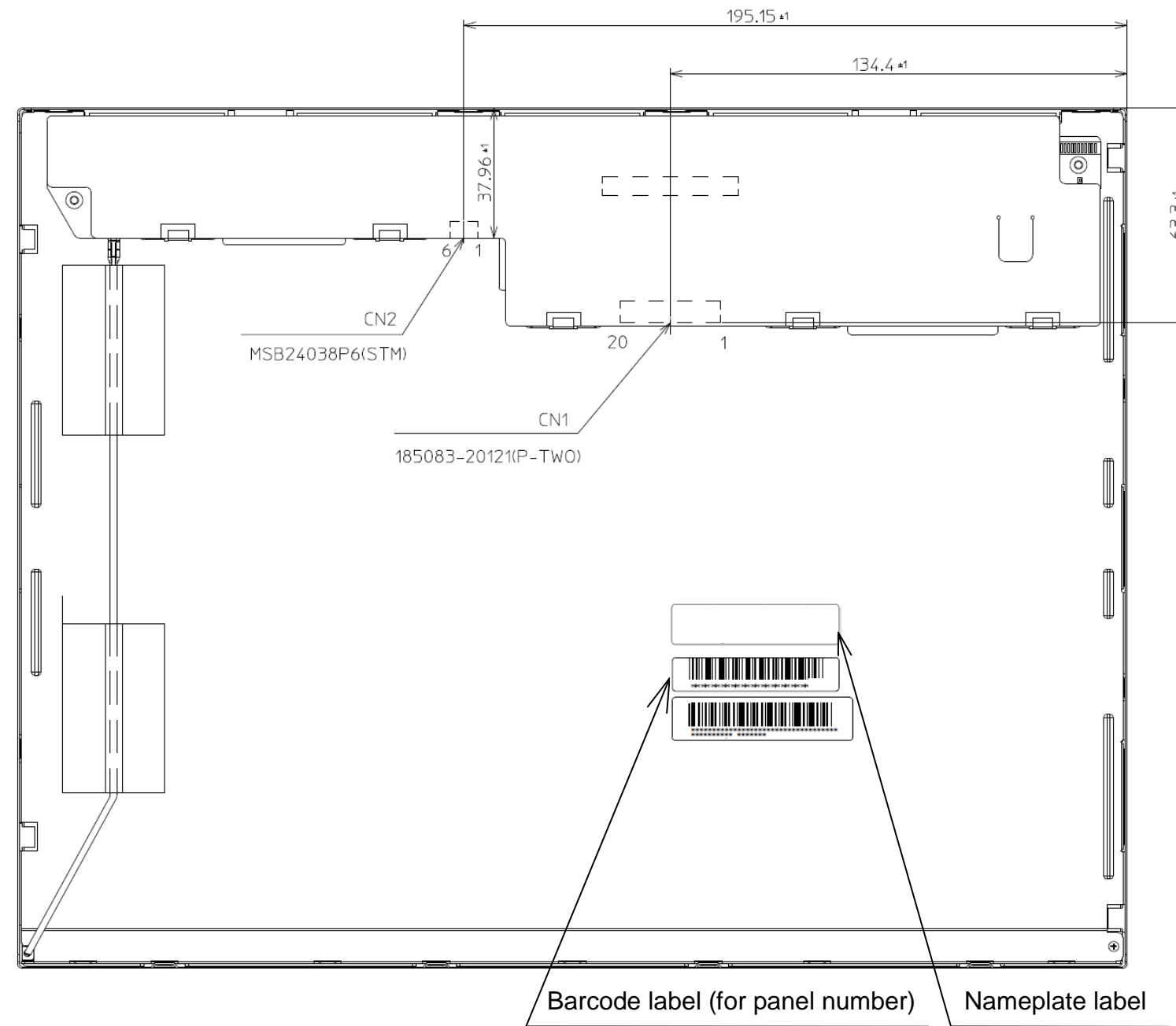

Note1: The torque for product mounting screws must never exceed 0.392N·m. And the length of product mounting screws must be ≤ 4.5 mm.

Unit: mm

Our company network supports you worldwide with offices in Germany, Austria, Switzerland, the UK and the USA. For more information please contact:

## Headquarters

### Germany



#### FORTEC Elektronik AG

Lechwiesenstr. 9  
86899 Landsberg am Lech

Phone: +49 8191 91172-0  
E-Mail: [sales@forteca.de](mailto:sales@forteca.de)  
Internet: [www.forteca.de](http://www.forteca.de)

## Fortec Group Members

### Austria



#### FORTEC Elektronik AG

##### Office Vienna

Nuschinggasse 12  
1230 Wien

Phone: +43 1 8673492-0  
E-Mail: [office@fortec.at](mailto:office@fortec.at)  
Internet: [www.fortec.at](http://www.fortec.at)

### Germany



#### Distec GmbH

Augsburger Str. 2b  
82110 Germering

Phone: +49 89 894363-0  
E-Mail: [info@distec.de](mailto:info@distec.de)  
Internet: [www.distec.de](http://www.distec.de)

### Switzerland



#### ALTRAC AG

Bahnhofstraße 3  
5436 Würenlos

Phone: +41 44 7446111  
E-Mail: [info@altrac.ch](mailto:info@altrac.ch)  
Internet: [www.altrac.ch](http://www.altrac.ch)

### United Kingdom



#### Display Technology Ltd.

Osprey House, 1 Osprey Court  
Hichingbrooke Business Park  
Huntingdon, Cambridgeshire, PE29 6FN

Phone: +44 1480 411600  
E-Mail: [info@displaytechnology.co.uk](mailto:info@displaytechnology.co.uk)  
Internet: [www.displaytechnology.co.uk](http://www.displaytechnology.co.uk)

### USA



#### Apollo Display Technologies, Corp.

87 Raynor Avenue,  
Unit 1 Ronkonkoma,  
NY 11779

Phone: +1 631 5804360  
E-Mail: [info@apolloDisplays.com](mailto:info@apolloDisplays.com)  
Internet: [www.apolloDisplays.com](http://www.apolloDisplays.com)