



OUR GLOBAL  
COMPETENCE  
CENTRES

 APOLLO DISPLAY  
TECHNOLOGIES



 DISTEC



 DISPLAY  
TECHNOLOGY



# Datasheet

## **ORTUSTECH**

### **COM43H4N02XLC**

The information contained in this document has been carefully researched and is, to the best of our knowledge, accurate. However, we assume no liability for any product failures or damages, immediate or consequential, resulting from the use of the information provided herein. Our products are not intended for use in systems in which failures of product could result in personal injury. All trademarks mentioned herein are property of their respective owners. All specifications are subject to change without notice.

---

# Specifications for

## Blanview TFT-LCD Monitor

Version 1.0

(Please be sure to check the specifications latest version.)

MODEL COM43H4N02XLC

Customer's Approval
Signature:
Name:
Section:
Title:
Date:

# ORTUSTECH

ORTUS TECHNOLOGY CO., LTD.

Approved by

M. Sugatani

Approved by

M. Mori

Checked by

O. Kimura

Prepared by

M. Tojo



## Contents

1. Application	.....	4
2. Outline Specifications		
2.1 Features of the Product	.....	5
2.2 Display Method	.....	5
3. Dimensions and Shape		
3.1 Dimensions	.....	7
3.2 Outward Form	.....	8
3.3 Serial Label (S-LABEL)	.....	9
4. Pin Assignment	.....	10
5. Absolute Maximum Rating	.....	11
6. Recommended Operating Conditions	.....	11
7. Characteristics		
7.1 DC Characteristics	.....	12
7.2 AC Characteristics	.....	12
7.3 Input Timing Characteristics	.....	14
7.4 Driving Timing Chart	.....	15
7.5 Example of Driving Timing Chart	.....	16
8. Description of Sequence		
8.1 Power ON/OFF Sequence	.....	17
8.2 Standby ON/OFF Sequence	.....	18
9. LED Circuit	.....	19
10. Characteristics		
10.1 Optical Characteristics	.....	20
10.2 Temperature Characteristics	.....	21
11. Criteria of Judgment		
11.1 Defective Display and Screen Quality	.....	22
11.2 Screen and Other Appearance	.....	23
12. Reliability Test	.....	24
13. Packing Specifications	.....	26
14. Handling Instruction		
14.1 Cautions for Handling LCD panels	.....	27
14.2 Precautions for Handling	.....	28
14.3 Precautions for Operation	.....	28
14.4 Storage Condition for Shipping Cartons	.....	29
14.5 Precautions for Peeling off the Protective film	.....	29
APPENDIX	.....	30

## 1. Application

This Specification is applicable to 10.9cm (4.3 inch) Blanview TFT-LCD monitor for non-military use.

- ◎ ORTUS TECHNOLOGY makes no warranty or assume no liability that use of this Product and/or any information including drawings in this Specification by Purchaser is not infringing any patent or other intellectual property rights owned by third parties, and ORTUS TECHNOLOGY shall not grant to Purchaser any right to use any patent or other intellectual property rights owned by third parties. Since this Specification contains ORTUS TECHNOLOGY's confidential information and copy right, Purchaser shall use them with high degree of care to prevent any unauthorized use, disclosure, duplication, publication or dissemination of ORTUS TECHNOLOGY'S confidential information and copy right.
- ◎ If Purchaser intends to use this Products for an application which requires higher level of reliability and/or safety in functionality and/or accuracy such as transport equipment (aircraft, train, automobile, etc.), disaster-prevention/security equipment or various safety equipment, Purchaser shall consult ORTUS TECHNOLOGY on such use in advance.
- ◎ This Product shall not be used for application which requires extremely higher level of reliability and/or safety such as aerospace equipment, telecommunication equipment for trunk lines, control equipment for nuclear facilities or life-support medical equipment.
- ◎ It must be noted as a mechanical design manner, especial attention in housing design to prevent arcuation/flexure or caused by stress to the LCD module shall be considered.
- ◎ ORTUS TECHNOLOGY assumes no liability for any damage resulting from misuse, abuse, and/or miss-operation of the Product deviating from the operating conditions and precautions described in the Specification.
- ◎ ORTUS TECHNOLOGY is not responsible for any nonconformities and defects that are not specified in this specifications.
- ◎ If any issue arises as to information provided in this Specification or any other information, ORTUS TECHNOLOGY and Purchaser shall discuss them in good faith and seek solution.
- ◎ ORTUS TECHNOLOGY assumes no liability for defects such as electrostatic discharge failure occurred during peeling off the protective film or Purchaser's assembly process.
- ◎ This Product is compatible for RoHS directive.

Object substance	Maximum content [ppm]
Cadmium and its compound	100
Hexavalent Chromium Compound	1000
Lead & Lead compound	1000
Mercury & Mercury compound	1000
Polybrominated biphenyl series (PBB series)	1000
Polybrominated biphenyl ether series (PBDE series)	1000



<Features of Blanview>

- Backlight power consumption required to assure visibility. (equivalent to 3.5"QVGA )

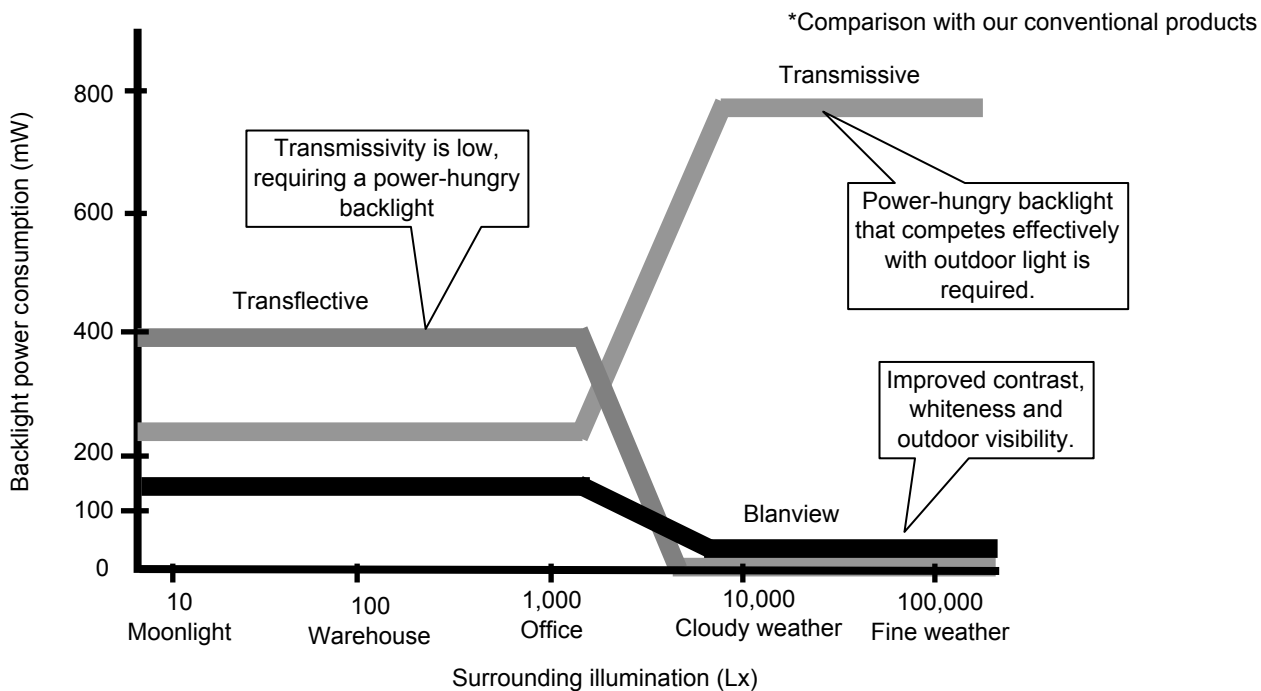

- Contrast characteristics under 100,000Lx. (same condition as direct sunlight.)

With better contrast (higher contrast ratio), Blanview TFT-LCD has the best outdoor readability in three different types of TFT-LCD.

Below chart shows contrast value against panel surface brightness. (Horizontal: Panel surface brightness/ Vertical: Contrast value) LCD panel has enough outdoor readability above our Standard line. (ORTUS TECHNOLOGY criteria)

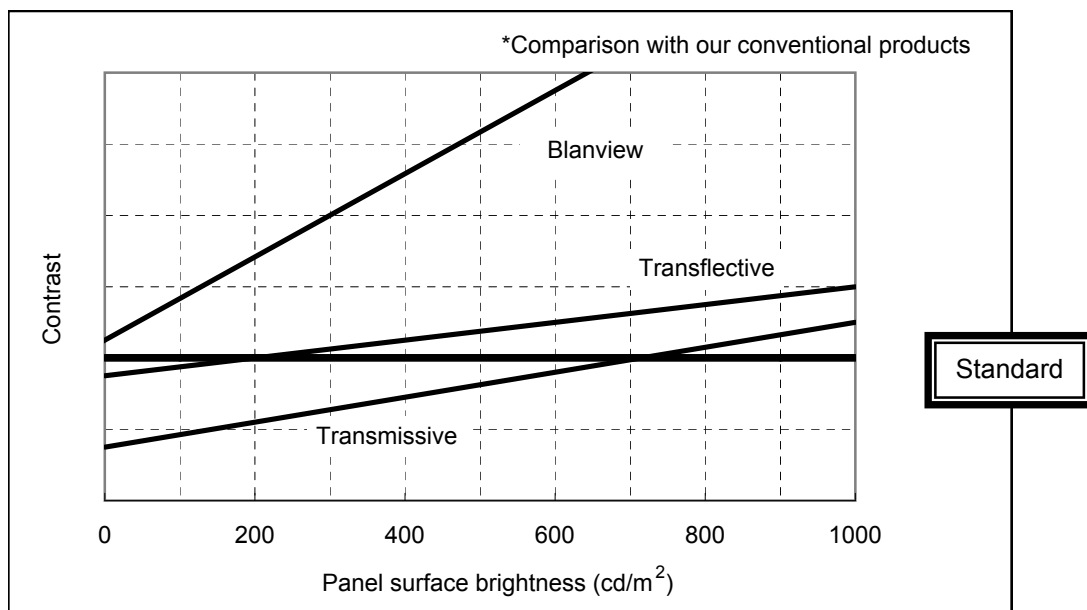



## 3. Dimensions and Shape

## 3.1 Dimensions

Items	Specifications	Unit	Remarks
Outline dimensions	105.50[H] × 67.20[V] × 2.90[D]	mm	Exclude FPC cable.
Active area	95.040[H] × 53.856[V]	mm	10.9cm diagonal.
Number of dots	1,440[H] × 272[V]	dot	
Dot pitch	66.0[H] × 198.0[V]	μm	
Surface hardness of the polarizer	3	H	Load:2.0N
Weight	40.0	g	Include FPC cable.

EC No.	REV.No.	REVISE	DATE (Y:M:D)	APPROVED	CHECKED	PREPARED
--------	---------	--------	--------------	----------	---------	----------

3.2 Outward Form

(8/32)  
14TLM061  
Issue: Jun. 10, 2015

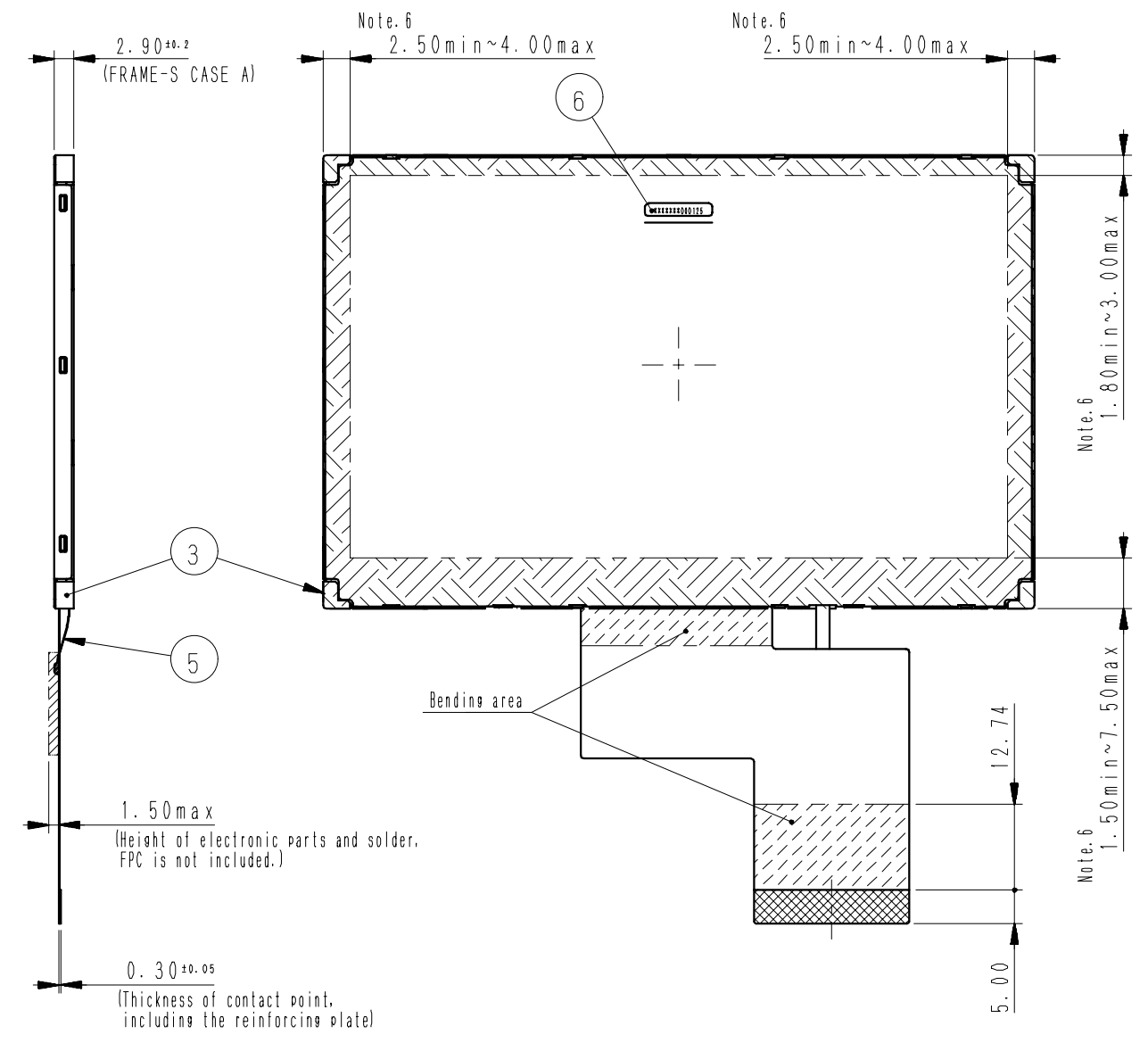
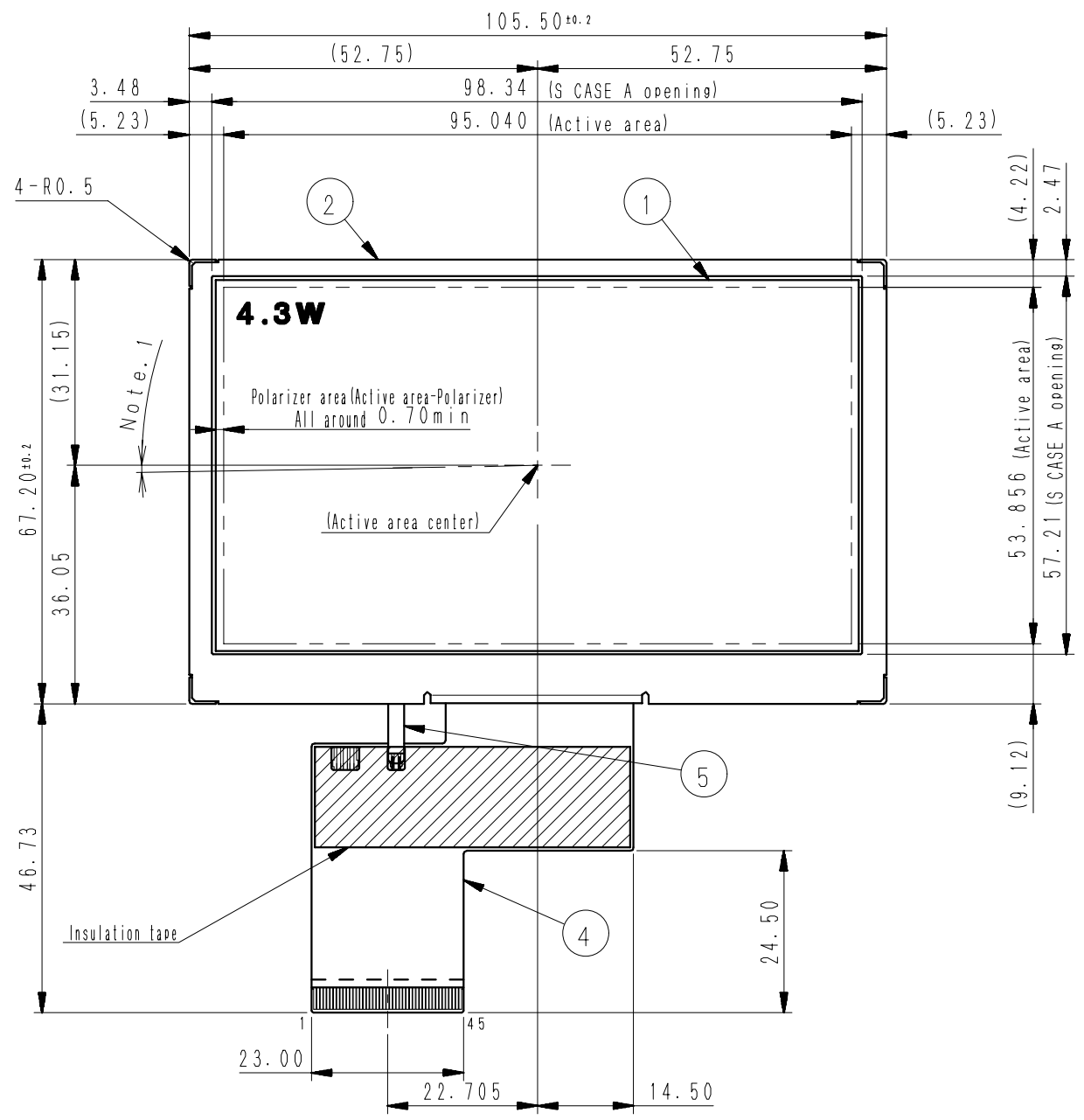

- Note.1 Angular deviation of LCD cell from the TFT-LCD monitor's reference axis shall be less than  $\pm 40'$ .
- Note.2 S label is affixed the area shown in the drawing. The thickness of the S label will be added to that of S case's surface.
- Note.3 Recommended FPC connectors  
For LCD : HIROSE/FH12A-45S-0.5SH (55) (Top contact)  
FPC pin assignment differs from a position of Datum Pin of recommended FPC connector. Please notice the difference when designing your circuit with much care.
- Note.4 Protective film is affixed on front surface of the screen. Location tolerance of the protective film shall be  $\pm 1.5$  mm to the polarizer.
- Note.5 Exercise care not to apply any forces to the cable holder of the S CASE A.
- Note.6 In case TFT-LCD monitor is fixed to the case of your product, it's recommended that monitor is fixed in to area.
- Note.7 Refer to "11.CRITERIA OF JUDGMENT" about the appearance specification of a polarizer.

	8			
	7			
S LABEL	6			(10×1.85×0.075t)
LED FPC	5			
LCD FPC	4			
FRAME	3			
S CASE A	2			
TFT-LCD PANEL	1			Glass substrate thickness=0.5t
PART NAME	ITEM	PART CODE	MATERIAL GRADE	REMARK

APPROVED 橋爪	GENERAL TOLERANCE $\pm 0.5$	SCALE 1/1	UNIT mm	<b>ORTUSTECH</b> ORTUS TECHNOLOGY CO., LTD. DO NOT DUPLICATE, CONFIDENTIAL AND PROPRIETARY	
CHECKED 平信	ISSUE (Y:M:D) 15:05:26	MODEL COM43H4N02X**			
CHECKED	NAME			DRAWING No.	
DESIGN 原田竜仁				REV.	SHEET
DRAW 原田竜仁					DIV.
OUTLINE-D4N02				RJD527101D301	

### 3.3 Serial Label (S-LABEL)

#### 1) Display Items

S-label indicates the least significant digit of manufacture year (1digit), manufacture month with below alphabet (1letter), model code (5characters), serial number (6digits).

\* Contents of Display

*	*	*****	*****
-	-	-	-
a	b	c	d

Contents of display				
a	The least significant digit of manufacture year			
b	Manufacture month	Jan-A Feb-B Mar-C Apr-D	May-E Jun-F Jul-G Aug-H	Sep-I Oct-J Nov-K Dec-L
c	Model code	43EBC (Made in Japan) 43ECC (Made in Malaysia)		
d	Serial number			

\* Example of indication of Serial label (S-label)

•Made in Japan

5K43EBC000125

means "manufactured in November 2015, model 4.3" EB, C specifications, serial number 000125"

•Made in Malaysia

5K43ECC000125

means "manufactured in November 2015, model 4.3" EC, C specifications, serial number 000125"

#### 2) Location of Serial Label (S-label)

Refer to 3.2 "Outward Form".

## 4. Pin Assignment

No.	Symbol	Function	
1	VSS	GND.	
2	VSS	GND.	
3	VDD	Power supply.	
4	VDD	Power supply.	
5	D00	Display data(R). 00h: Black D00:LSB D07:MSB  Driver has internal gamma conversion.	
6	D01		
7	D02		
8	D03		
9	D04		
10	D05		
11	D06		
12	D07	Display data(G). 00h: Black D10:LSB D17:MSB  Driver has internal gamma conversion.	
13	D10		
14	D11		
15	D12		
16	D13		
17	D14		
18	D15		
19	D16	Display data(B). 00h: Black D20:LSB D27:MSB  Driver has internal gamma conversion.	
20	D17		
21	D20		
22	D21		
23	D22		
24	D23		
25	D24		
26	D25	GND.	
27	D26		
28	D27		
29	VSS		
30	CLK		Clock signal.Latching data at the falling edge.
31	STBYB		Standby signal input. (Hi:Normal operation, Lo:Standby operation)
32	HSYNC		Horizontal sync signal input. (Low active)
33	VSYNC	Vertical sync signal input. (Low active)	
34	DE	Input data effective signal. (It is effective for the period of "Hi")	
35	NC	OPEN.	
36	VSS	GND.	
37	NC	OPEN.	
38	NC	OPEN.	
39	NC	OPEN.	
40	NC	OPEN.	
41	VSS	GND.	
42	BLL	Backlight drive (cathode side)	
43	BLH	Backlight drive (anode side)	
44	NC	OPEN.	
45	NC	OPEN.	

- Recommended connector: HIROSE ELECTRIC FH12 series [FH12A-45S-0.5SH(55)]
- Please make sure to check a consistency between pin assignment in "3.2 Outward Form" and your connector pin assignment when designing your circuit.  
Inconsistency in input signal assignment may cause a malfunction.
- Since FPC cable has gold plated terminals, gilt finish contact shoe connector is recommended.

## 5. Absolute Maximum Rating

VSS=0V

Item	Symbol	Condition	Rating		Unit	Applicable terminal	
			MIN	MAX			
Supply voltage	VDD	Ta=25°C	-0.3	5.0	V	VDD	
Input voltage for logic	VI		-0.3	VDD+0.3	V	CLK,VSYNCR,HSYNCR,DE D[27:20],D[17:10],D[07:00], STBYB	
LED direction current of order	IL	Ta=25°C	--	35	mA	BLH - BLL	
		Ta=70°C	--	15			
Storage temperature range	Tstg		-30	80	°C		
Storage humidity range	Hstg	Non condensing in an environmental moisture at or less than 40°C90%RH.					

## 6. Recommended Operating Conditions

VSS=0V

Item	Symbol	Condition	Rating			Unit	Applicable terminal
			MIN	TYP	MAX		
Supply voltage	VDD		3.0	3.3	3.6	V	VDD
Input voltage for logic	VI	VDD=3.0~ 3.6V	0	--	VDD	V	CLK,VSYNCR,HSYNCR, DE,D[27:20],D[17:10], D[07:00],STBYB
Operating temperatur range	Top	Note 1,2	-20	25	70	°C	Panel surface temperature
Operating humidity range	Hop	Ta ≤ 30°C	20	--	80	%	
		Ta > 30°C	Non condensing in an environmental moisture at or less than 30°C80%RH.				

Note1: This monitor is operable in this temperature range. With regard to optical characteristics, refer to Item "10. CHARACTERISTICS".

Note2: Acceptable Forward Current to LED is up to 15mA, when Ta=+70°C.  
Do not exceed Allowable Forward Current shown on the chart below.

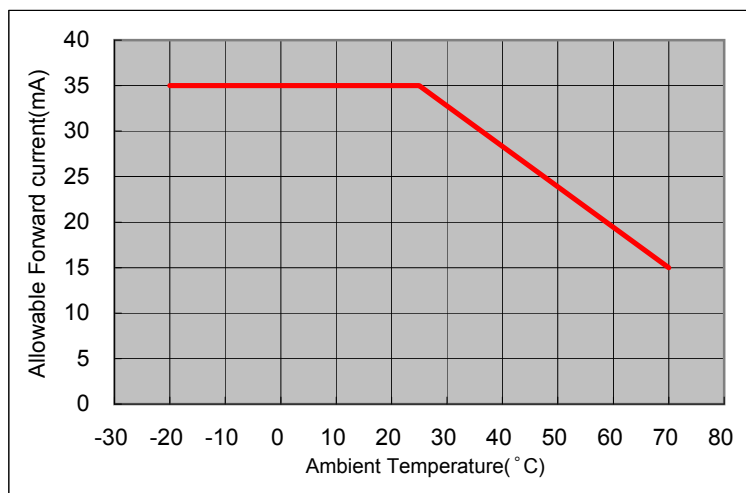

## 7. Characteristics

## 7.1 DC Characteristics

## 7.1.1 Display Module

(Unless otherwise noted, Ta=25°C, VDD=3.3V, VSS=0V)

Item	Symbol	Condition	Rating			Unit	Applicable terminal
			MIN	TYP	MAX		
Input voltage for logic	VIH	VDD=3.0~3.6V	0.7×VDD	--	VDD	V	CLK, VSYNC, HSYNC, DE, D[27:20], D[17:10], D[07:00], STBYB
	VIL		0	--	0.3×VDD	V	
Pull down resistor value	Rpd		--	200	--	kΩ	DE, D[27:20], D[17:10], D[07:00]
Pull up resistor value	Rpu		--	200	--	kΩ	VSYNC, HSYNC, STBYB
Current consumption	IDD	fCLK=9MHz Color bar display	--	17	34	mA	VDD
Standby Current	IDDs	Other input with constant voltage	--	100	200	μA	

## 7.1.2 Backlight

Item	Symbol	Condition	Rating			Unit	Applicable terminal
			MIN	TYP	MAX		
Forward current	IL25	Ta=25°C	--	6.5	35.0	mA	BLH - BLL
	IL70	Ta=70°C	--	--	15.0	mA	
Forward voltage	VL	Ta=25°C, IL=6.5mA	--	24.1	26.9	V	
Estimated Life of LED	LL	Ta=25°C, IL=6.5mA Note	--	(20,000)	--	hr	

Note: - The lifetime of the LED is defined as a period till the brightness of the LED decreases to the half of its initial value.

- This figure is given as a reference purpose only, and not as a guarantee.

- This figure is estimated for an LED operating alone.

As the performance of an LED may differ when assembled as a monitor together with a TFT panel due to different environmental temperature.

- Estimated lifetime could vary on a different temperature and usually higher temperature could reduce the life significantly.

## 7.2 AC Characteristics

(Unless otherwise noted, Ta=25°C, VDD=3.3V, VSS=0V)

Item	Symbol	Condition	Rating			Unit	Applicable terminal
			MIN	TYP	MAX		
CLK frequency	fCLK		5.0	9.0	12.0	MHz	CLK
CLK rising time	tr	10%→90%	--	--	9	ns	
CLK falling time	tf	90%→10%	--	--	9	ns	
CLK Low period	tw1L	0.3×VDD or less.	0.4/fCLK	--	0.6/fCLK	ns	
CLK High period	tw1H	0.7×VDD or more.	0.4/fCLK	--	0.6/fCLK	ns	
Setup time	tsp		12.0	--	--	ns	CLK, VSYNC, HSYNC, DE, D[27:20], D[17:10], D[07:00]
Hold time	thd		12.0	--	--	ns	

Switching Waveform Characteristics

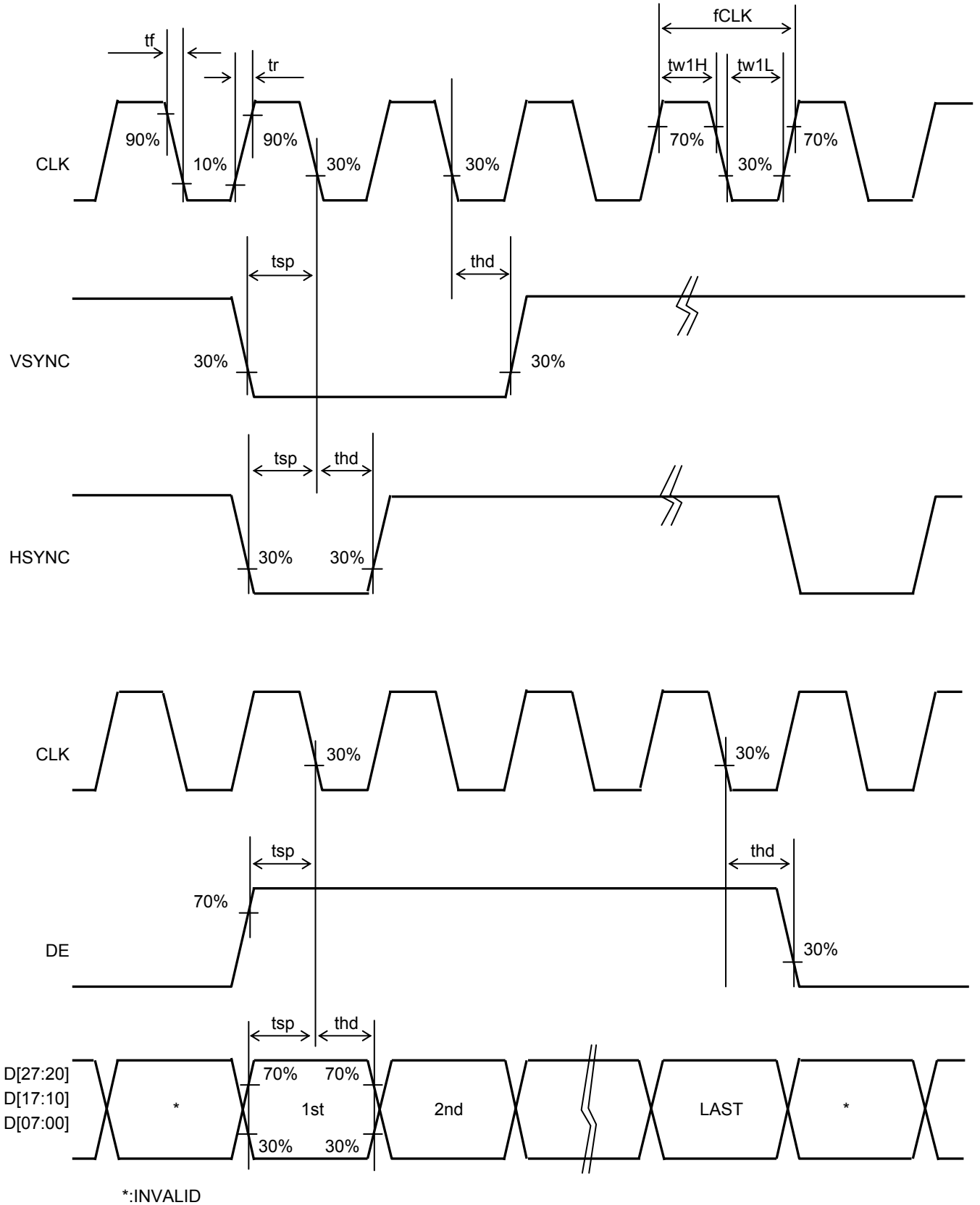

## 7.3 Input Timing Characteristics

(Unless otherwise noted, Ta=25 °C, VDD=3.3V, VSS=0V)

Item	Symbol	Rating			Unit	Applicable terminal
		MIN	TYP	MAX		
VSYNC frequency	Note fVSYNC	54	60	66	Hz	VSYNC
VSYNC signal cycle time	tv	277	288	400	H	VSYNC,HSYNC
VSYNC pulse width	tw2H	1	--	--	H	
Vertical back porch	tvb	3	8	31	H	
Vertical front porch	tvf	2	8	93	H	
Vertical display period	tvdp	--	272	--	H	
HSYNC frequency	fHSYNC	15.38	16.67	18.18	Khz	VSYNC,HSYNC,DE,D[27:20], D[17:10],D[07:00]
HSYNC signal cycle time	th	520	525	800	CLK	HSYNC,CLK
HSYNC pulse width	tw3H	1	--	--	CLK	
Horizontal back porch	thb	36	40	255	CLK	HSYNC,DE,CLK
Horizontal front porch	thf	4	5	65	CLK	
Horizontal display period	thdp	--	480	--	CLK	DE,D[27:20],D[17:10],D[07:00], CLK
DE pulse width	tw4H	--	480	--	CLK	DE,CLK

Note: The characteristic of this item is recommended standard.

Please use it after it confirms it enough like the display fineness etc.

When it comes off from this characteristic and it is used.



### 7.4 Driving Timing Chart

#### -Vertical Timing

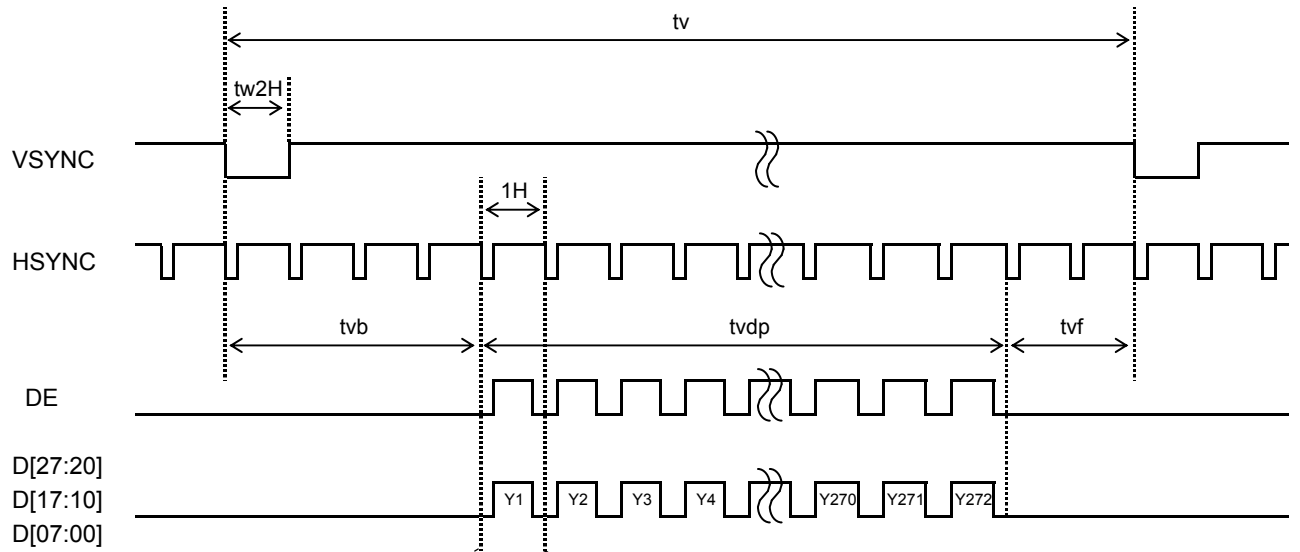

#### -Horizontal Timing

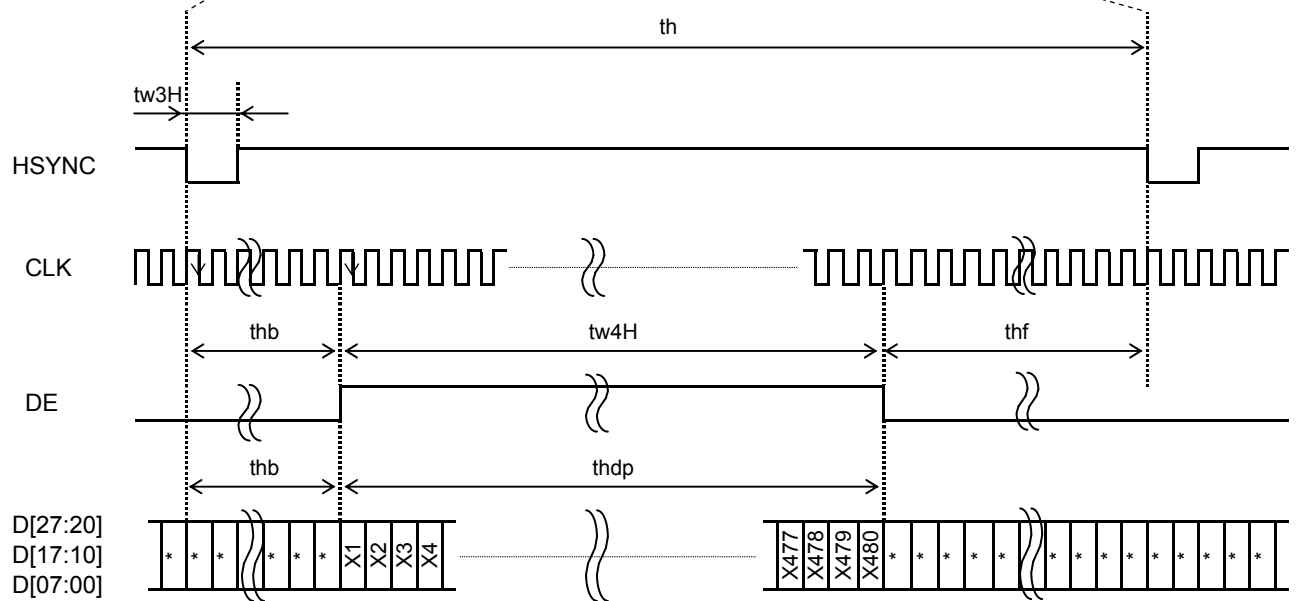

7.5 Example of Driving Timing Chart (fCLK=9.0MHz)

-Vertical Timing

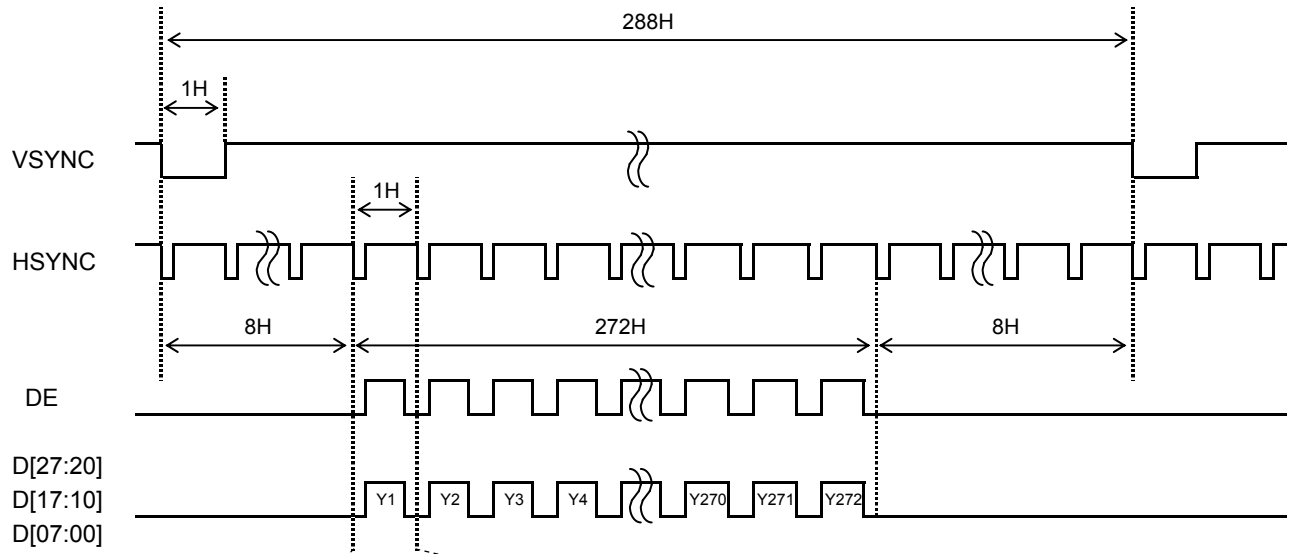

-Horizontal Timing

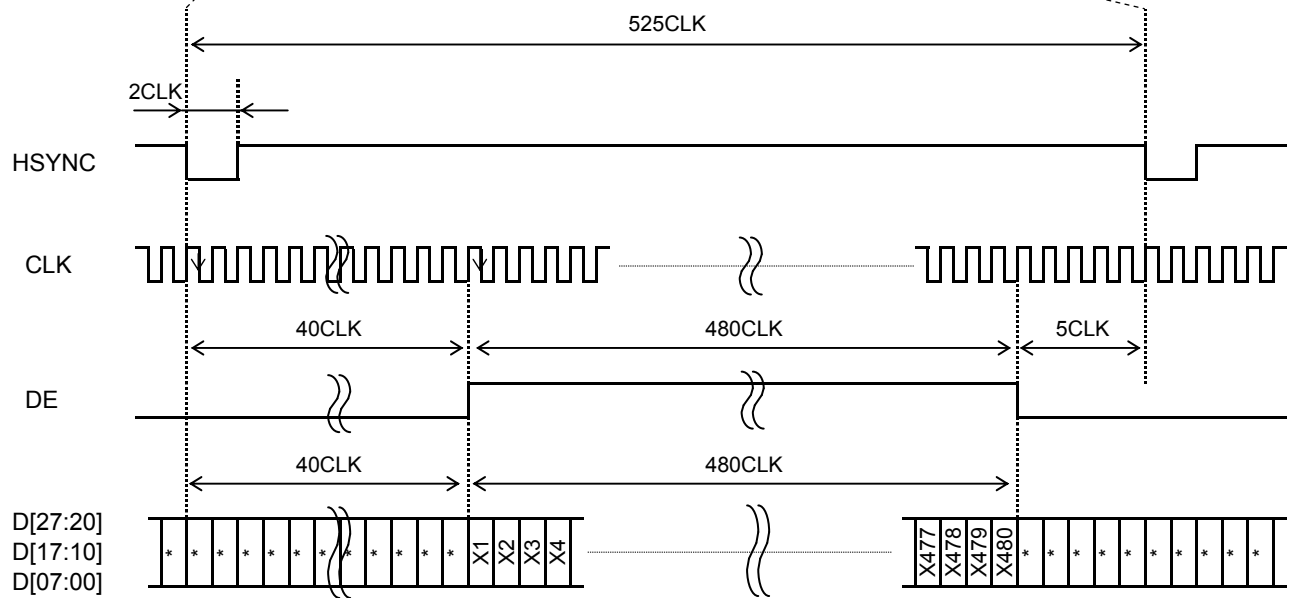

### 8. Description of Sequence

The outline of "Power ON/OFF Sequence" and "Standby ON/OFF Sequence" is shown below.

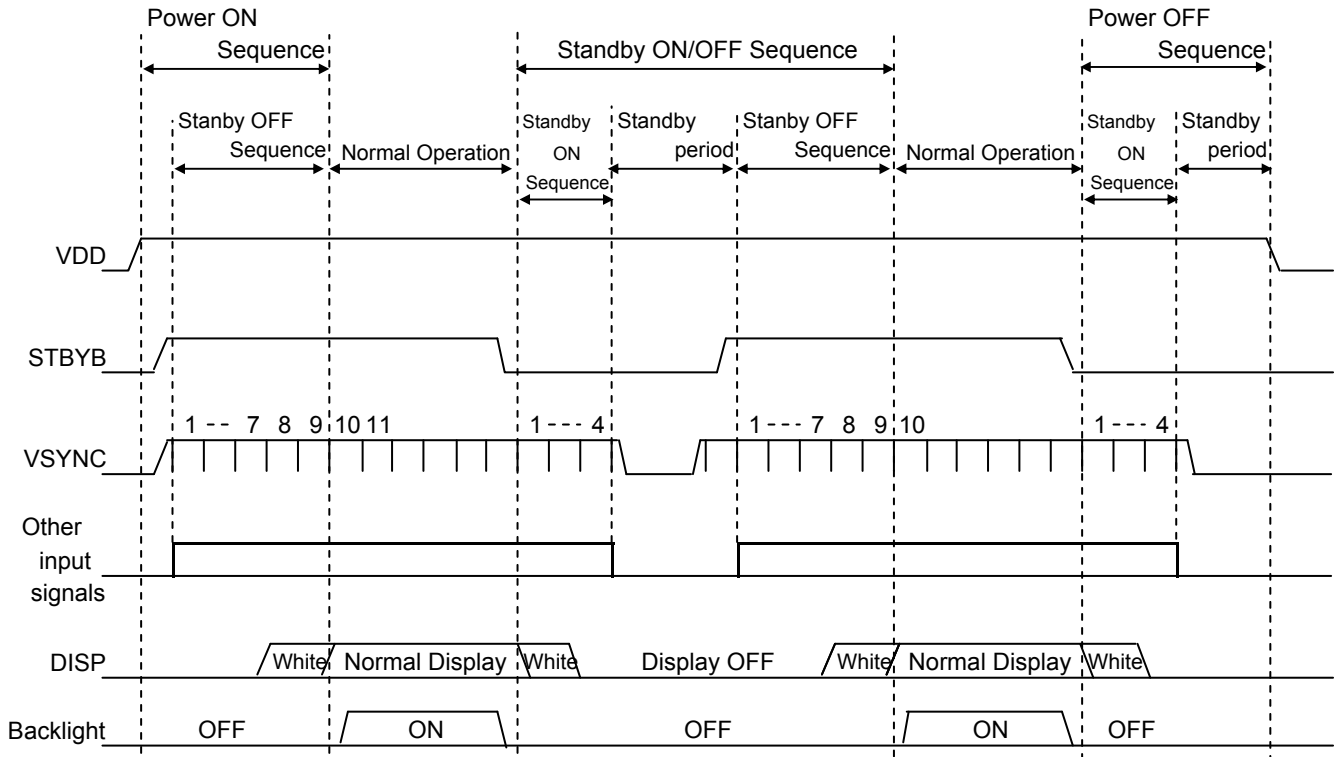

#### 8.1 Power ON/OFF Sequence

The sequence of the Power On/Off and the signal input must defend the following conditions.

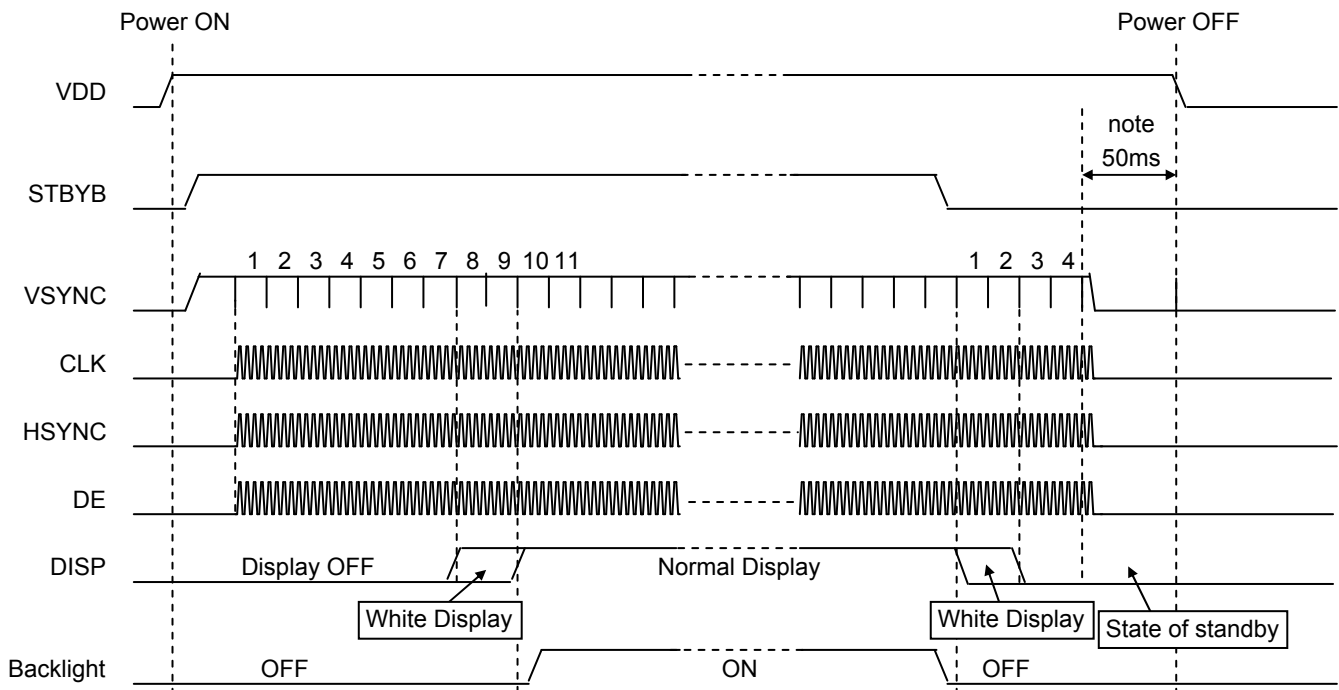

Note: For Power OFF, please turn off VDD since 50msec after the standby state shifts.  
 When CLK and the VSYNC signal are stopped or the power supply is turned off to a regulated frame or less, the afterimage might remain.

### 8.2 Standby ON/OFF Sequence

It explains Standby ON/OFF sequence by the STBYB signal.

The following time will be needed by the shift in the state of the standby from the standby setting according to the STBYB signal.

Meanwhile, VSYNC signal and the CLK signal should keep being supplied.

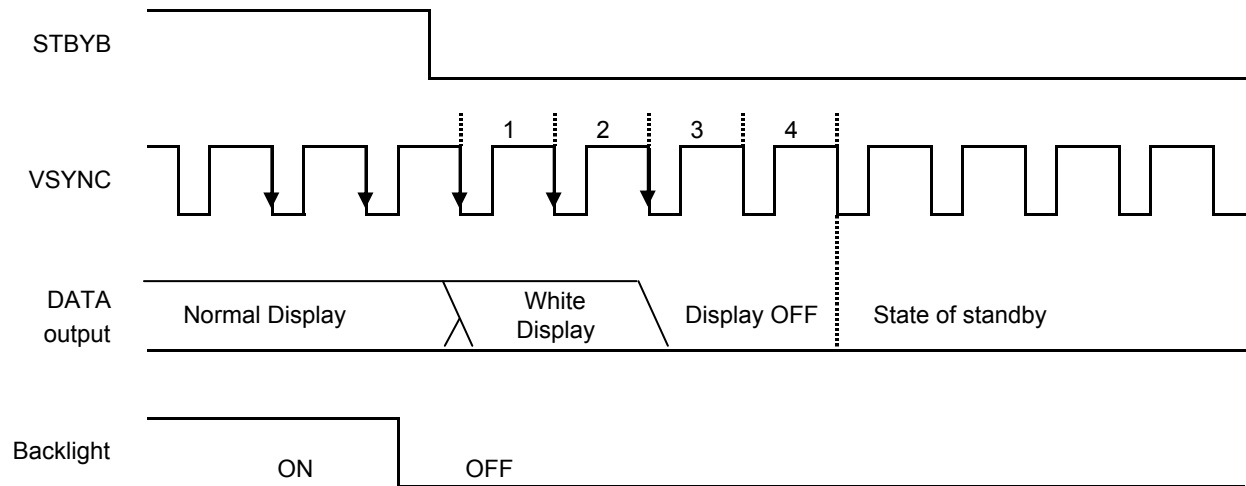

Similarly, the time of nine frames will be needed by the time a usual display is begun from the standby release by the STBYB signal.

Please begin outputting in the 8th frame on the Display Data.

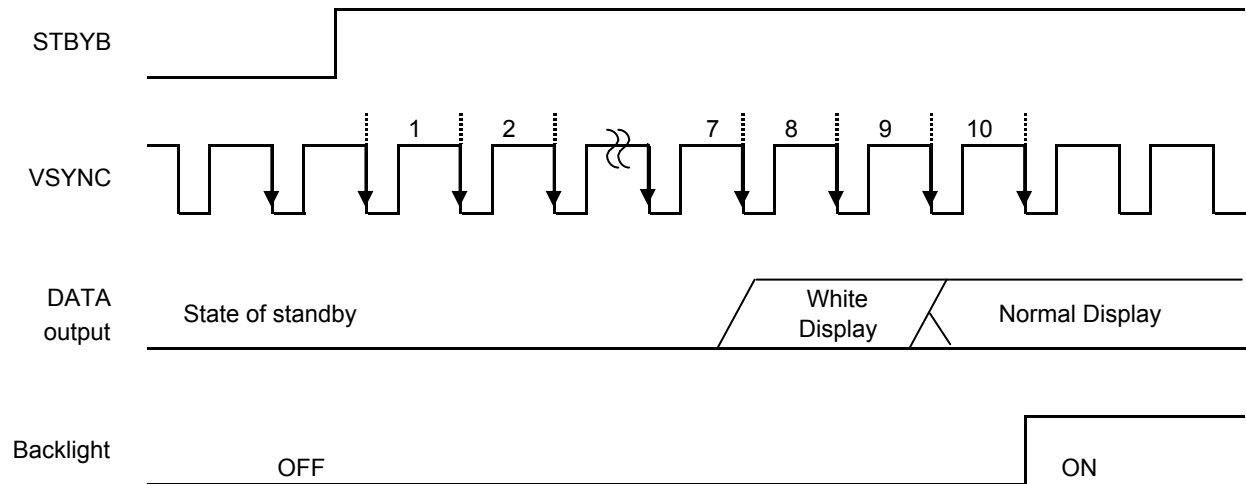

9. LED Circuit

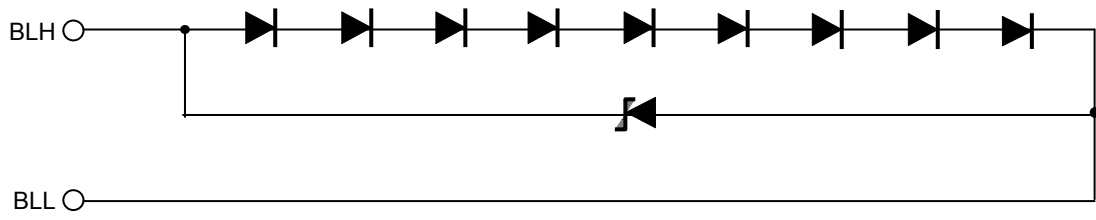

## 10. Characteristics

## 10.1 Optical Characteristics

&lt; Measurement Condition &gt;

Measuring instruments: CS1000 (KONICA MINOLTA) , LCD7200(OTSUKA ELECTRONICS) ,  
EZcontrast160D (ELDIM)

Driving condition: VDD = 3.3V, VSS=0V  
Optimized VCOMDC

Backlight: IL=6.5mA

Measured temperature: Ta=25° C

Item	Symbol	Condition	MIN	TYP	MAX	Unit	Note No.	Remark	
Response time	Rise time	TON [Data]=FFh→00h	—	—	40	ms	1	※	
	Fall time	TOFF [Data]=00h→FFh	—	—	60	ms			
Contrast ratio	Backlight ON	CR [Data]=FFh/00h	240	400	—		2		
	Backlight OFF		—	7.5	—				
Viewing angle	Left	θL [Data]=FFh/00h CR≥10	80	—	—	deg	3	※	
	Right		θR	80	—	—			deg
	Up		φU	80	—	—			deg
	Down		φD	80	—	—			deg
White Chromaticity	x	[Data]=FFh	White chromaticity range				4		
	y								
Burn-in			No noticeable burn-in image shall be observed after 2 hours of window pattern display.				5		
Center brightness		[Data]=FFh	315	450	—	cd/m <sup>2</sup>	6		
Brightness distribution		[Data]=FFh	70	—	—	%	7		

\* Note number 1 to 7: Refer to the APPENDIX of "Reference Method for Measuring Optical Characteristics".

※ Measured in the form of LCD module.

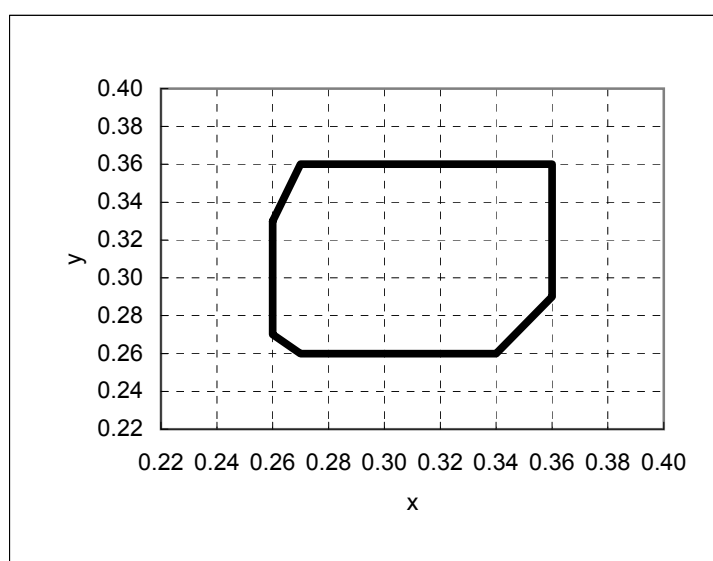

【White Chromaticity Range】

x	y
0.26	0.33
0.26	0.27
0.27	0.26
0.34	0.26
0.36	0.29
0.36	0.36
0.27	0.36

White Chromaticity Range

## 10.2 Temperature Characteristics

&lt; Measurement Condition &gt;

Measuring instruments: CS1000 (KONICA MINOLTA) , LCD7200(OTSUKA ELECTRONICS)

Driving condition: VDD = 3.3V, VSS=0V

Optimized VCOMDC

Backlight: IL=6.5mA

Item			Specification		Remark
			Ta = -20° C	Ta = 70° C	
Contrast ratio		CR	40 or more	40 or more	Backlight ON
Response time	Rise time	TON	200 msec or less	30 msec or less	※
	Fall time	TOFF	300 msec or less	50 msec or less	※
Display Quality			No noticeable display defect or nonuniformity should be observed.		Use the criteria for judgment specified in the section 11.

※ Measured in the form of LCD module.

## 11. Criteria of Judgment

## 11.1 Defective Display and Screen Quality

Test Condition:	Observed TFT-LCD monitor from front during operation with the following conditions
Driving Signal	Raster Patter (RGB, white, black)
Signal condition	[Data]:FFh, 70h, 00h (3 steps)
Observation distance	30 cm
Illuminance	200 to 350 lx
Backlight	IL=6.5mA

Defect item	Defect content	Criteria		
Display Quality	Line defect	Black, white or color line, 3 or more neighboring defective dots	Not exists	
	Dot defect	Uneven brightness on dot-by-dot base due to defective TFT or CF, or dust is counted as dot defect (brighter dot, darker dot)	Refer to table 1	
		High bright dot: Visible through 2% ND filter at [Data]=00h	ignored	
		Low bright dot: Visible through 5% ND filter at [Data]=00h Dark dot: Appear dark through white display at [Data]=70h Invisible through 5% ND filter at [Data]=00h		
Screen Quality	Dirt	Uneven brightness (white stain, black stain etc)	Invisible through 1% ND filter	
	Foreign particle	Point-like	$0.25\text{mm} < \varphi$	$N=0$
			$0.20\text{mm} < \varphi \leq 0.25\text{mm}$	$N \leq 2$
			$\varphi \leq 0.20\text{mm}$	Ignored
		Liner	$3.0\text{mm} < \text{length and } 0.08\text{mm} < \text{width}$	$N=0$
	$\text{length} \leq 3.0\text{mm}$ or $\text{width} \leq 0.08\text{mm}$		Ignored	
Others		Use boundary sample for judgment when necessary		

$\varphi(\text{mm})$ : Average diameter = (major axis + minor axis)/2

Permissible number: N

Table 1

Area	High bright dot	Low bright dot	Dark dot	Total	Criteria
A	0	2	2	3	Permissible distance between same color bright dots (includes neighboring dots): 3 mm or more Permissible distance between same color high bright dots (includes neighboring dots): 5 mm or more
B	2	4	4	6	
Total	2	4	4	7	

<Landscape model>

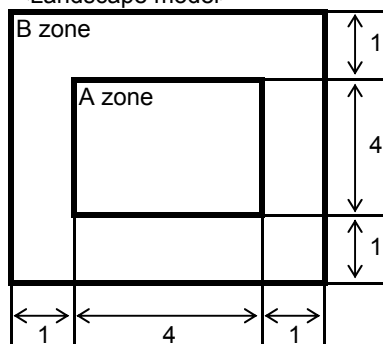

Division of A and B areas

B area: Active area

Dimensional ratio between A and B areas: 1: 4: 1 (Refer to the left figure)



## 11.2 Screen and Other Appearance

## Testing conditions

Observation distance	30cm
Illuminance	1200~2000 lx

Item		Criteria	Remark
Polarizer	Flaw	Ignore invisible defect when the backlight is on.	Applicable area: Active area only (Refer to the section 3.2 "Outward form")
	Stain		
	Bubble		
	Dust		
	Dent		
S-case		No functional defect occurs	
FPC cable		No functional defect occurs	

## 12. Reliability Test

Test item		Test condition		number of failures /number of examinations
Durability test	High temperature storage	Ta=80° C	240hr	0/3
	Low temperature storage	Ta=-30° C	240hr	0/3
	High temperature & high humidity storage	Ta=60° C, RH=90% non condensing	240hr	0/3
	High temperature operation	Tp=70° C	240hr	0/3
	Low temperature operation	Tp=-20° C	240hr	0/3
	High temp & humid operation	Tp=40° C, RH=90% non condensing	240hr	0/3
	Thermal shock storage	-30←→80° C(30min/30min)	100 cycles	0/3
Mechanical environmental test	Electrostatic discharge test (Non operation)	Confirms to EIAJ ED-4701/300 C=200pF,R=0Ω,V=±200V Each 3 times of discharge on and power supply and other terminals.		0/3
	Surface discharge test (Non operation)	C=250pF, R=100Ω, V=±12kV Each 5 times of discharge in both polarities on the center of screen with the case grounded.		0/3
	FPC tension test	Pull the FPC with the force of 3N for 10 sec. in the direction - 90-degree to its original direction.		0/3
	FPC bend test	Pull the FPC with the force of 3N for 10 sec. in the direction -180-degree to its original direction. Reciprocate it 3 times.		0/3
	Vibration test	Total amplitude 1.5mm, f=10~55Hz, X,Y,Z directions for each 2 hours		0/3
	Impact test	Use ORTUS TECHNOLOGY original jig (see next page) and make an impact with peak acceleration of 1000m/s <sup>2</sup> for 6 msec with half sine-curve at 3 times to each X, Y, Z directions in conformance with JIS 60068-2-27-2011.		0/3
Packing test	Packing vibration-proof test	Acceleration of 19.6m/s <sup>2</sup> with frequency of 10→55→10Hz, X,Y, Zdirection for each 30 minutes		0/1 Packing
	Packing drop test	Drop from 75cm high. 1 time to each 6 surfaces, 3 edges, 1 corner		0/1 Packing

Note: Ta=ambient temperature Tp=Panel temperature

※ The profile of high temperature/humidity storage and High Temperature/humidity operation (Pure water of over 10MΩ·cm shall be used.)

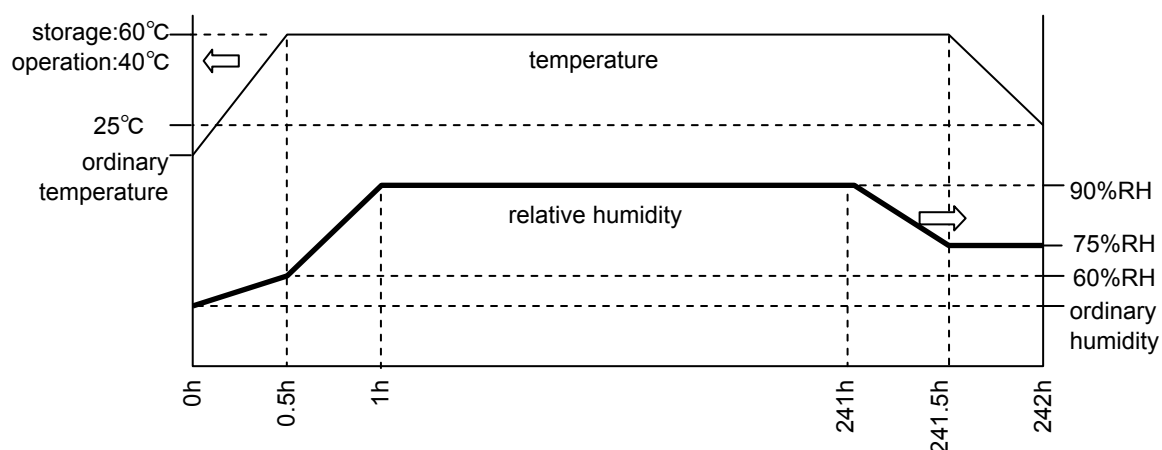
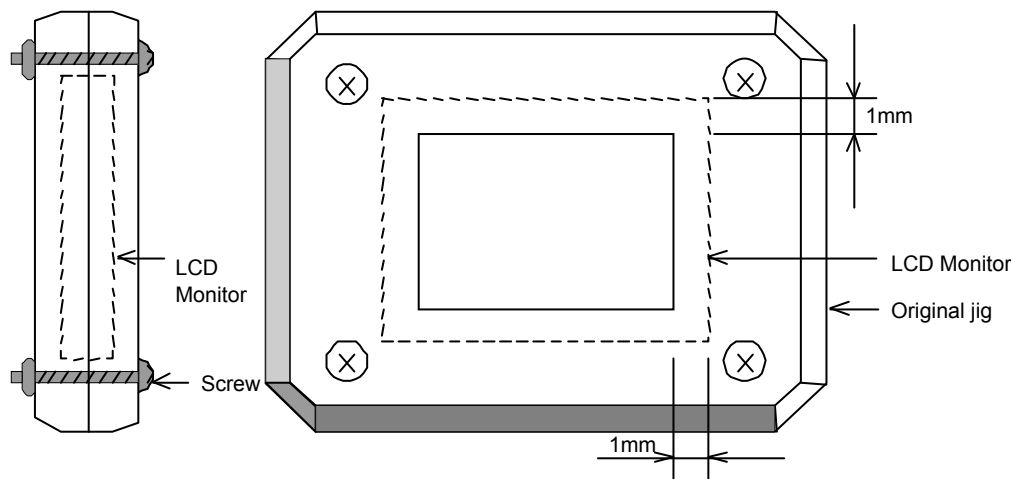

Table2.Reliability Criteria

Measure the parameters after leaving the monitor at the ordinary temperature for 24 hours or more after the test completion.

item	Standard	Remarks
Display quality	No visible abnormality shall be seen.	As criteria of "11 Criteria of Judgment".
Contrast ratio	40 or more	Backlight ON

ORTUS TECHNOLOGY Original Jig



Tension Test Method for FPC cable

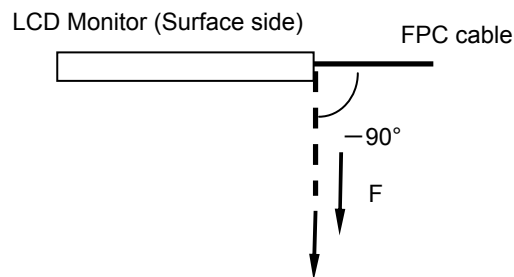

Bend Test Method for FPC cable

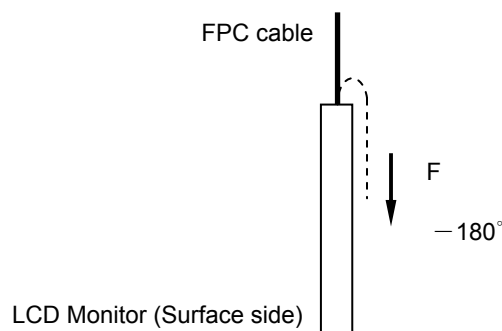

### 13. Packing Specifications

Packing specification  
(S=FREE)

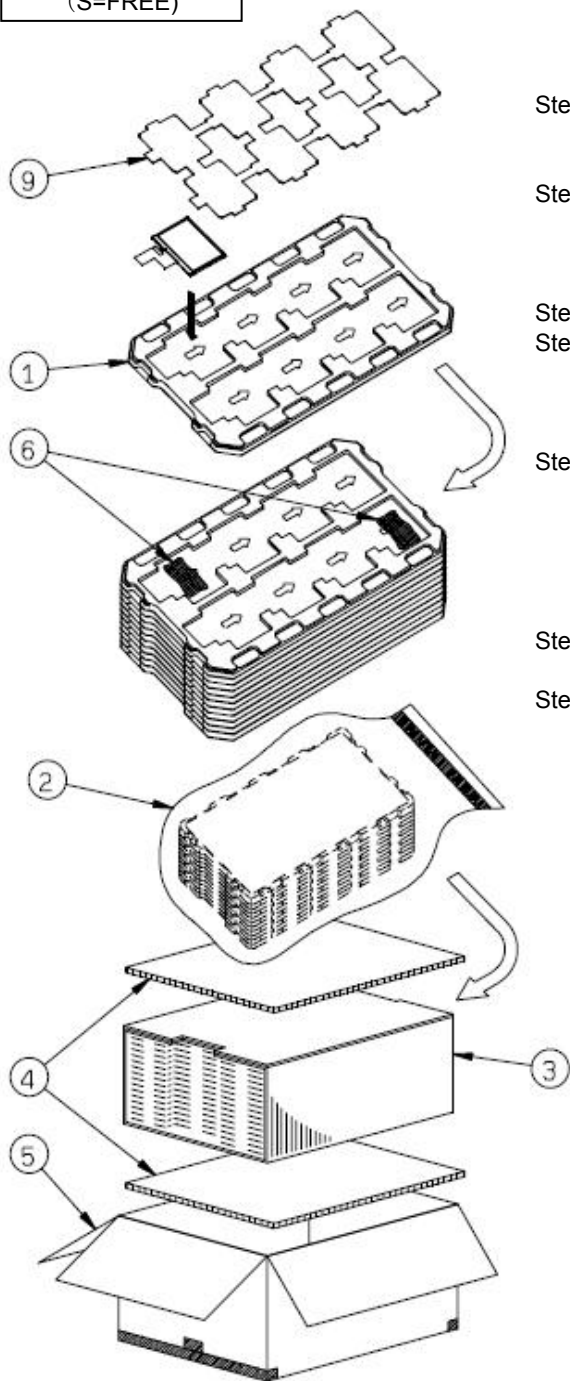

- Step 1. Each product is to be placed in one of the cut-outs of the tray with the display surface facing upward.  
(8products per tray)  
Foam sheet is put on the products.
- Step 2. Each tray is to be piled up in same direction and the trays be in a stack of 10.  
One empty tray is to be put on the top of stack of 10 trays.
- Step 3. 2 packs of moisture absorbers are to be placed on the top tray as shown in the drawing.  
Put piled trays into a sealing bag.  
Vacuum and seal the sealing bag with the vacuum sealing machine.
- Step 4. The stack of trays in the sealing back is to be inserted into a carton box.
- Step 5. A corrugated board is to be placed in the bottom of an outer carton.  
The carton box is to be put on the corrugated board in the outer carton.  
Another corrugated board is to be placed on the top of the inserted carton box.
- Step 6. The outer carton is to be sealed in H-shape with packing tape as shown in the drawing.  
The model number, quantity of products, and shipping date are to be printed on the 2 opposite sides of the outer carton with black ink.  
If necessary, shipping labels or impression markings are to be put on the outer carton.
- Step 7. The outer carton is to be inserted into an extra outer carton with same direction.
- Step 8. The extra outer carton is to be sealed in H-shape with packing tape as shown in the drawing.  
The model number, quantity of products, and shipping date are to be printed on the 2 opposite sides of the outer carton with black ink.  
If necessary, shipping labels or impression markings are to be put on the extra outer carton.

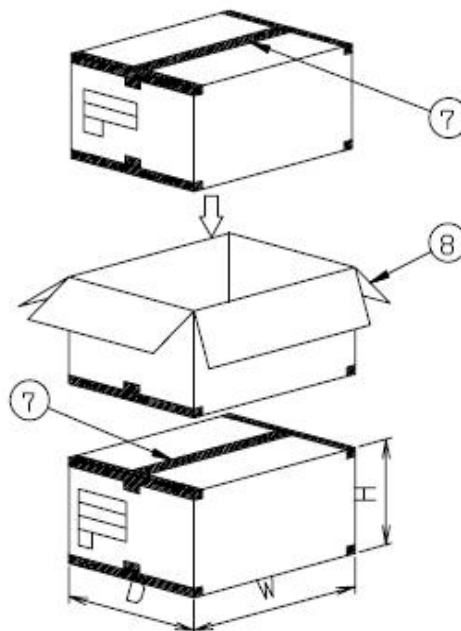

Remark: The return of packing materials is not required.

Packing item name	Specs., Material
① Tray	A-PET Antistatic
② Sealing bag	
③ Carton box	Corrugated cardboard
④ Inner board	Corrugated cardboard
⑤ Outer carton	Corrugated cardboard
⑥ Drier	Moisture absorber
⑦ Packing tape	
⑧ Extra outer carton	Corrugated cardboard
⑨ Foam sheet	PE Anti-static

Dimension of extra outer carton	
D : Approx.	(338mm)
W : Approx.	(549mm)
H : Approx.	(198mm)
Quantity of products packed in one carton:	80
Gross weight : Approx.	6.7Kg

## 14. Handling Instruction

## 14.1 Cautions for Handling LCD panels

**Caution**

- (1) Do not make an impact on the LCD panel glass because it may break and you may get injured from it.
- (2) If the glass breaks, do not touch it with bare hands.  
(Fragment of broken glass may stick you or you cut yourself on it.)
- (3) If you get injured, receive adequate first aid and consult a medial doctor.
- (4) Do not let liquid crystal get into your mouth.  
(If the LCD panel glass breaks, try not let liquid crystal get into your mouth even toxic property of liquid crystal has not been confirmed.)
- (5) If liquid crystal adheres, rinse it out thoroughly.  
(If liquid crystal adheres to your cloth or skin, wipe it off with rubbing alcohol or wash it thoroughly with soap. If liquid crystal gets into eyes, rinse it with clean water for at least 15 minutes and consult an eye doctor.)
- (6) If you scrap this products, follow a disposal standard of industrial waste that is legally valid in the community, country or territory where you reside.
- (7) Do not connect or disconnect this product while its application products is powered on.
- (8) Do not attempt to disassemble or modify this product as it is precision component.
- (9) If a part of soldering part has been exposed, and avoid contact (short-circuit) with a metallic part of the case etc. about FPC of this model, please.  
Please insulate it with the insulating tape etc. if necessary.  
The defective operation is caused, and there is a possibility to generation of heat and the ignition.
- (10) Since excess current protection circuit is not built in this TFT module, there is the possibility that LCD module or peripheral circuit become feverish and burned in case abnormal operation is generated.  
We recommend you to add excess current protection circuit to power supply.

**Caution**

**This mark is used to indicate a precaution or an instruction which, if not correctly observed, may result in bodily injury, or material damages alone.**

## 14.2 Precautions for Handling

- 1) Wear finger tips at incoming inspection and for handling the TFT monitors to keep display quality and keep the working area clean.  
Do not touch the surface of the monitor as it is easily scratched.
- 2) Wear grounded wrist-straps and use electrostatic neutralization blowers to prevent static charge and discharge when handling the TFT monitors as the LED in this TFT monitors is damageable to electrostatic discharge,  
Properly set up equipment, jigs and machines, and keep working area clean and tidy for handling the TFT monitors.
- 3) Avoid strong mechanical shock including knocking, hitting or dropping to the TFT monitors for protecting their glass parts. Do not use the TFT monitors that have been experienced dropping or strong mechanical shock.
- 4) Do not use or storage the TFT monitors at high temperature and high humidity environment. Particularly, never use or storage the TFT monitors at a location where condensation builds up.
- 5) Avoid using and storing TFT monitors at a location where they are exposed to direct sunlight or ultraviolet rays to prevent the LCD panels from deterioration by ultraviolet rays.
- 6) Do not stain or damage the contacts of the FPC cable .  
FPC cable needs to be inserted until it can reach to the end of connector slot.  
During insertion, make sure to keep the cable in a horizontal position to avoid an oblique insertion.  
Otherwise, it may cause poor contact or deteriorate reliability of the FPC cable.
- 7) Do not bend or pull the FPC cable or carry the TFT monitor by holding the FPC cable.
- 8) Peel off the protective film on the TFT monitors during mounting process.  
Refer to the section 14.5 on how to peel off the protective film.  
We are not responsible for electrostatic discharge failures or other defects occur when peeling off the protective film.

## 14.3 Precautions for Operation

- 1) Since this TFT monitors are not equipped with light shielding for the driver IC, do not expose the driver IC to strong lights during operation as it may cause functional failures.
- 2) In case of powering up or powering off this LCD module, be sure to comply the sequence as instructed in this specification.
- 3) Do not plug in or out the FPC cable while power supply is switch on.  
Plug the FPC cable in and out while power supply is switched off.
- 4) Do not operate the TFT monitors in the strong magnetic field. It may break the TFT monitors.
- 5) Do not display a fixed image on the screen for a long time.  
Use a screen-saver or other measures to avoid a fixed image displayed on the screen for a long time. Otherwise, it may cause burn-in image on the screen due the characteristics of liquid crystal.

#### 14.4 Storage Condition for Shipping Cartons

##### Storage environment

- Temperature 0 to 40° C
- Humidity 60%RH or less  
No-condensing occurs under low temperature with high humidity condition.
- Atmosphere No poisonous gas that can erode electronic components and/or wiring materials should be detected.
- Time period 3 months
- Unpacking  
To protect the TFT monitors from static damage during unpacking, keep room humidity more than 50%RH and implement effective countermeasures against static electricity such as establishing a ground (an earth) before unpacking.
- Maximum piling up 7 cartons

#### 14.5 Precautions for Peeling off the Protective film

The followings work environment and work method are recommended to prevent the TFT monitors from static damage or adhesion of dust when peeling off the protective films.

##### A) Work Environment

- a) Humidity: 50 to 70 %RH, Temperature 15 to 27° C
- b) Operators should wear conductive shoes, conductive clothes, conductive finger tips and grounded wrist-straps. Anti-static treatment should be implemented to work area's floor.
- c) Use a room shielded against outside dust with sticky floor mat laid at the entrance to eliminate dirt.

##### B) Work Method

The following procedures should taken to prevent the driver ICs from charging and discharging.

- a) Use an electrostatic neutralization blower to blow air on the TFT monitors to its lower right when the FPC cable is facing to the downside.  
Optimize direction of the blowing air and the distance between the TFT monitors and the electrostatic neutralization blower.
- b) Put an adhesive tape (Scotch tape, etc) at the lower right corner area of the protective film to prevent scratch on surface of TFT monitor.
- c) Peel off the adhesive tape slowly (spending more than 2 seconds to complete) by pulling it to opposite direction.

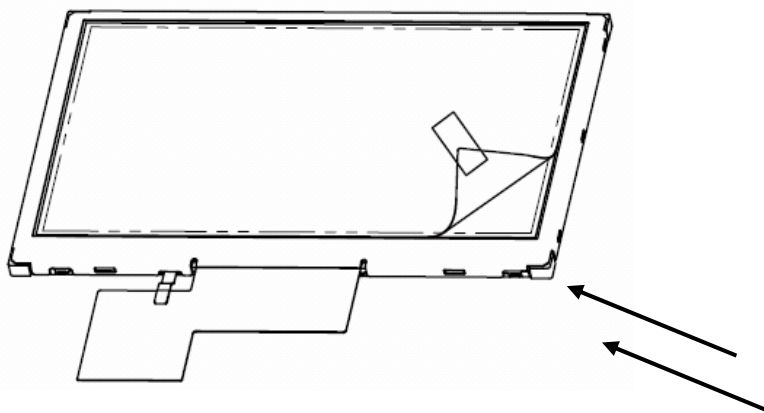

Direction of blowing air  
(Optimize air direction and the distance)

**APPENDIX**

Reference Method for Measuring Optical Characteristics and Performance

1. Measurement Condition (Backlight ON)

Measuring instruments: CS1000 (KONICA MINOLTA) , LCD7200(OTSUKA ELECTRONICS) ,EZcontrast160D (ELDIM)

Driving condition: Refer to the section "Optical Characteristics"

Measured temperature: 25° C unless specified

Measurement system: See the chart below. The luminance meter is placed on the normal line of measurement system.

Measurement point: At the center of the screen unless otherwise specified

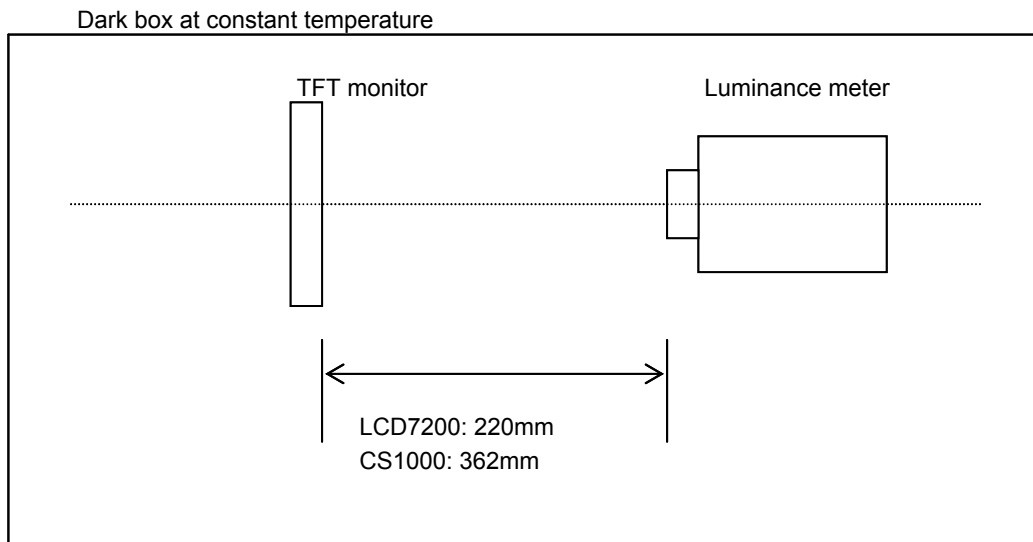

Measurement is made after 30 minutes of lighting of the backlight.

Measurement point: At the center point of the screen  
Brightness distribution: 9 points shown in the following drawing.

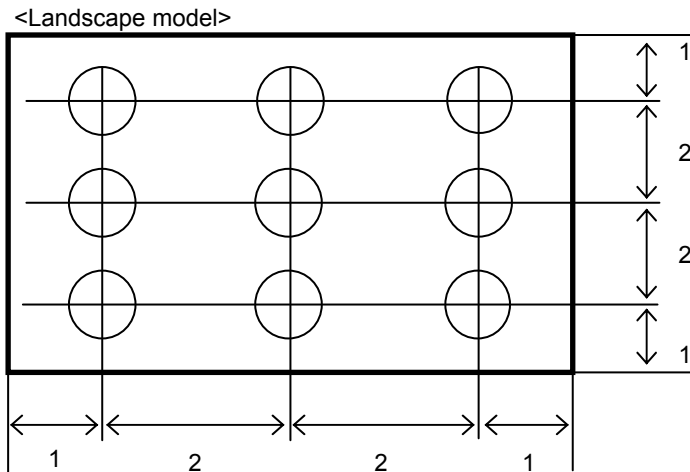

Dimensional ratio of active area

Backlight IL=6.5mA



## Measurement Condition (Contrast ratio Backlight OFF only)

Measuring instruments: LCD7200(OTSUKA ELECTRONICS),Ring Light(40,000 lx, $\phi$ 58)

Driving condition: Refer to the section "Optical Characteristics"

Measured temperature: 25° C unless specified

Measurement system: See the chart below.

Measurement point: At the center of the screen.

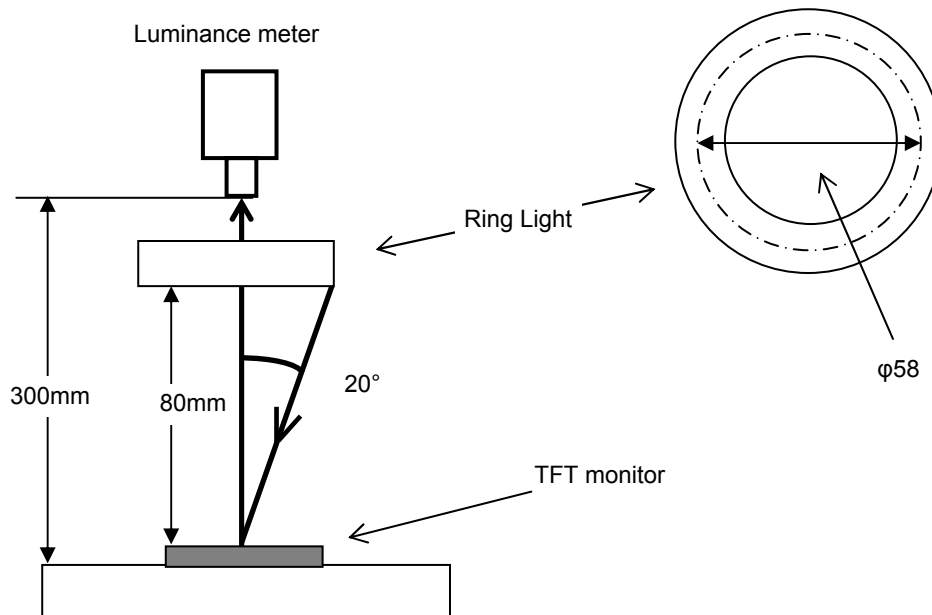

## 2. Test Method

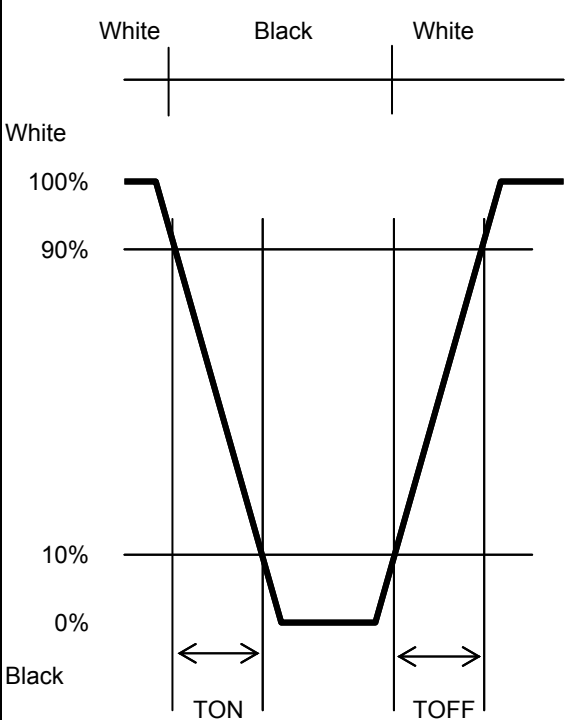
Notice	Item	Test method	Measuring instrument	Remark
1	Response time	<p>Measure output signal waveform by the luminance meter when raster of window pattern is changed from white to black and from black to white.</p> 	LCD7200	<p>Black display [Data]=00h White display [Data]=FFh TON Rise time TOFF Fall time</p>
2	Contrast ratio	<p>Measure maximum luminance Y1([Data]=FFh) and minimum luminance Y2([Data]=00h) at the center of the screen by displaying raster or window pattern. Then calculate the ratio between these two values.</p> <p>Contrast ratio = Y1/Y2</p> <p>Diameter of measuring point: 8mmφ(CS1000)</p> <p>Diameter of measuring point: 8mmφ(LCD7200)</p>	CS1000 LCD7200	Backlight ON Backlight OFF
3	Viewing angle Horizontalθ Verticalφ	Move the luminance meter from right to left and up and down and determine the angles where contrast ratio is 10.	EZcontrast160D	
4	White chromaticity	<p>Measure chromaticity coordinates x and y of CIE1931 colorimetric system at [Data] = FFh</p> <p>Color matching faction: 2°view</p>	CS1000	
5	Burn-in	Visually check burn-in image on the screen after 2 hours of "window display" ([Data]=FFh/00h).		At optimized VCOMDC
6	Center brightness	Measure the brightness at the center of the screen.	CS1000	
7	Brightness distribution	<p>(Brightness distribution) = 100 x B/A %</p> <p>A : max. brightness of the 9 points</p> <p>B : min. brightness of the 9 points</p>	CS1000	

Our company network supports you worldwide with offices in Germany, Austria, Switzerland, the UK and the USA. For more information please contact:

## Headquarters

Germany



**FORTEC Elektronik AG**

Lechwiesenstr. 9  
86899 Landsberg am Lech

Phone: +49 8191 91172-0  
E-Mail: [sales@forteca.de](mailto:sales@forteca.de)  
Internet: [www.forteca.de](http://www.forteca.de)

## Fortec Group Members

Austria



**FORTEC Elektronik AG**

**Office Vienna**

Nuschinggasse 12  
1230 Wien

Phone: +43 1 8673492-0  
E-Mail: [office@fortec.at](mailto:office@fortec.at)  
Internet: [www.fortec.at](http://www.fortec.at)

Germany



**Distec GmbH**

Augsburger Str. 2b  
82110 Germering

Phone: +49 89 894363-0  
E-Mail: [info@distec.de](mailto:info@distec.de)  
Internet: [www.distec.de](http://www.distec.de)

Switzerland



**ALTRAC AG**

Bahnhofstraße 3  
5436 Würenlos

Phone: +41 44 7446111  
E-Mail: [info@altrac.ch](mailto:info@altrac.ch)  
Internet: [www.altrac.ch](http://www.altrac.ch)

United Kingdom



**Display Technology Ltd.**

Osprey House, 1 Osprey Court  
Hichingbrooke Business Park  
Huntingdon, Cambridgeshire, PE29 6FN

Phone: +44 1480 411600  
E-Mail: [info@displaytechnology.co.uk](mailto:info@displaytechnology.co.uk)  
Internet: [www.displaytechnology.co.uk](http://www.displaytechnology.co.uk)

USA



**Apollo Display Technologies, Corp.**

87 Raynor Avenue,  
Unit 1 Ronkonkoma,  
NY 11779

Phone: +1 631 5804360  
E-Mail: [info@apolloDisplays.com](mailto:info@apolloDisplays.com)  
Internet: [www.apolloDisplays.com](http://www.apolloDisplays.com)